

BAS-326G PS

Please read this manual before using the machine.
Please keep this manual within easy reach for quick reference.

DIRECT DRIVE
PROGRAMMABLE ELECTRONIC PATTERN SEWER
<PERFECT STITCH>



Thank you very much for buying a BROTHER sewing machine. Before using your new machine, please read the safety instructions below and the explanations given in the instruction manual.

With industrial sewing machines, it is normal to carry out work while positioned directly in front of moving parts such as the needle and thread take-up lever, and consequently there is always a danger of injury that can be caused by these parts. Follow the instructions from training personnel and instructors regarding safe and correct operation before operating the machine so that you will know how to use it correctly.



SAFETY INSTRUCTIONS

[1] Safety indications and their meanings

This instruction manual and the indications and symbols that are used on the machine itself are provided in order to ensure safe operation of this machine and to prevent accidents and injury to yourself or other people.

The meanings of these indications and symbols are given below.

Indications

 DANGER	The instructions which follow this term indicate situations where failure to follow the instructions may result in death or serious injury.
 CAUTION	The instructions which follow this term indicate situations where failure to follow the instructions could cause injury when using the machine or physical damage to equipment and surroundings.

Symbols



..... This symbol () indicates something that you should be careful of. The picture inside the triangle indicates the nature of the caution that must be taken.
(For example, the symbol at left means “beware of injury”.)



..... This symbol () indicates something that you must not do.



..... This symbol () indicates something that you must do. The picture inside the circle indicates the nature of the thing that must be done.
(For example, the symbol at left means “you must make the ground connection”.)

[2] Notes on safety

DANGER



Wait at least 5 minutes after turning off the power switch and disconnecting the power cord from the wall outlet before opening the cover of the control box. Touching areas where high voltages are present can result in severe injury.

CAUTION

Environmental requirements



Use the sewing machine in an area which is free from sources of strong electrical noise such as electrical line noise or static electric noise.

Sources of strong electrical noise may cause problems with correct operation.



Any fluctuations in the power supply voltage should be within $\pm 10\%$ of the rated voltage for the machine. Voltage fluctuations which are greater than this may cause problems with correct operation.



The power supply capacity should be greater than the requirements for the sewing machine's power consumption.

Insufficient power supply capacity may cause problems with correct operation.



The pneumatic delivery capability should be greater than the requirements for the sewing machine's total air consumption.

Insufficient pneumatic delivery capability may cause problems with correct operation.



The ambient temperature should be within the range of 5°C to 35°C during use.

Temperatures which are lower or higher than this may cause problems with correct operation.



The relative humidity should be within the range of 45% to 85% during use, and no dew formation should occur in any devices.

Excessively dry or humid environments and dew formation may cause problems with correct operation.



In the event of an electrical storm, turn off the power and disconnect the power cord from the wall outlet.

Lightning may cause problems with correct operation.

Installation



Machine installation should only be carried out by a qualified technician.



Contact your Brother dealer or a qualified electrician for any electrical work that may need to be done.



The sewing machine weighs approximately 90 kg. The installation should be carried out by two or more people.



Do not connect the power cord until installation is complete. If the foot switch is depressed by mistake, the sewing machine might start operating and injury could result.



Hold the machine head with both hands when tilting it back or returning it to its original position.

Furthermore, do not apply excessive force when tilting back the machine head. The sewing machine may become unbalanced and fall down, and serious injury or damage to the sewing machine may result.



Be sure to connect the ground. If the ground connection is not secure, you run a high risk of receiving a serious electric shock, and problems with correct operation may also occur.



All cords should be secured at least 25 mm away from any moving parts. Furthermore, do not excessively bend the cords or secure them too firmly with staples, otherwise there is the danger that fire or electric shocks could occur.



Install the safety covers to the machine head and motor.



If using a work table which has casters, the casters should be secured in such a way so that they cannot move.











Be sure to wear protective goggles and gloves when handling the lubricating oil and grease, so that they do not get into your eyes or onto your skin. If the oil and grease get into your eyes or onto your skin, inflammation can result.



Furthermore, do not drink or eat the lubricating oil or grease. They may cause diarrhea or vomiting. Keep the oil out of the reach of children.

CAUTION









Sewing

-  This sewing machine should only be used by operators who have received the necessary training in safe use beforehand.
-  The sewing machine should not be used for any applications other than sewing.
-  Be sure to wear protective goggles when using the machine.
If goggles are not worn, there is the danger that if a needle breaks, parts of the broken needle may enter your eyes and injury may result.
-  Turn off the power switch at the following times. If the foot switch is depressed by mistake, the sewing machine might start operating and injury could result.
 - When threading the needle
 - When replacing the bobbin and needle
 - When not using the machine and when leaving the machine unattended
-  If using a work table which has casters, the casters should be secured in such a way so that they cannot move.
-  Attach all safety devices before using the sewing machine. If the machine is used without these devices attached, injury may result.
-  Do not touch any of the moving parts or press any objects against the machine while sewing, as this may result in personal injury or damage to the machine.
-  If an error occurs in machine operation, or if abnormal noises or smells are noticed, immediately turn off the power switch. Then contact your nearest Brother dealer or a qualified technician.
-  If the machine develops a problem, contact your nearest Brother dealer or a qualified technician.

Cleaning

-  Turn off the power switch before carrying out cleaning. If the foot switch is depressed by mistake, the sewing machine might start operating and injury could result.
-  Be sure to wear protective goggles and gloves when handling the lubricating oil and grease, so that they do not get into your eyes or onto your skin. If the oil and grease get into your eyes or onto your skin, inflammation can result.
Furthermore, do not drink or eat the lubricating oil or grease. They may cause diarrhea or vomiting.
Keep the oil out of the reach of children.

Maintenance and inspection

-  Maintenance and inspection of the sewing machine should only be carried out by a qualified technician.
-  Ask your Brother dealer or a qualified electrician to carry out any maintenance and inspection of the electrical system.
-  Turn off the power switch and disconnect the power cord before carrying out the following operations. If the foot switch is depressed by mistake, the sewing machine might start operating and injury could result.
 - Inspection, adjustment and maintenance
 - Replacing consumable parts such as the rotary hook
-  Disconnect the air hoses from the air supply and wait for the needle on the pressure gauge to drop to "0" before carrying out inspection, adjustment and repair of any parts which use the pneumatic equipment.
-  Hold the machine head with both hands when tilting it back or returning it to its original position.
Furthermore, do not apply excessive force when tilting back the machine head. The sewing machine may become unbalanced and fall down, and serious injury or damage to the sewing machine may result.
-  If the power switch needs to be left on when carrying out some adjustment, be extremely careful to observe all safety precautions.
-  Use only the proper replacement parts as specified by Brother.
-  If any safety devices have been removed, be absolutely sure to re-install them to their original positions and check that they operate correctly before using the machine.
-  Any problems in machine operation which result from unauthorized modifications to the machine will not be covered by the warranty.

[3] Warning labels

The following warning labels appear on the sewing machine.

Please follow the instructions on the labels at all times when using the machine. If the labels have been removed or are difficult to read, please contact your nearest Brother dealer.

1

	⚠ 危険 ⚠ 危険	
	高電圧部分にふれて、大けがをすることがある。電源を切り、5分たってからカバーをはずすこと。	触摸高压电部分, 会导致受伤。在切断电源5分钟后, 再开启盖罩。
⚠ DANGER ⚠ GEFAHR ⚠ DANGER ⚠ PELIGRO		
Hazardous voltage will cause injury. Turn off main switch and wait 5 minutes before opening this cover.	Hochspannung verletzungsgefahr! Bitte schalten sie den hauptschalter aus und warten sie 5 minuten, bevor sie diese abdeckung öffnen.	Un voltage non adapte provoque des blessures. Eteindre l'interrupteur et attendre 5 minutes avant d'ouvrir le capot.
		Un voltaje inadecuado puede provocar las heridas. Apagar el interruptor principal y esperar 5 minutos antes de abrir esta cubierta.

2

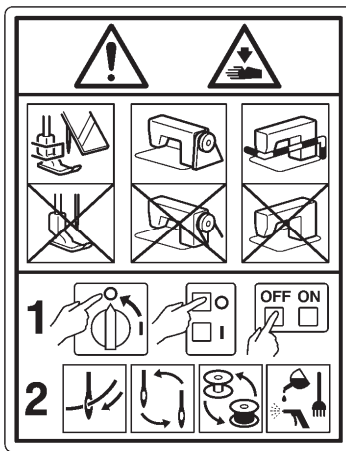

CAUTION

Moving parts may cause injury.

Operate with safety devices* installed.

Turn off the power before carrying out operations such as threading, changing the needle, bobbin, knives or hook, cleaning and adjusting.

*Safety devices

Devices such as eye guard, finger guard, thread take-up cover, motor cover, solenoid cover, tension release solenoid cover, inner cover, outer cover, fixed cover and gas spring support cover

3



Be careful not to get your hand caught when tilting back the machine head and returning it to its original position.

4



PE

Be sure to connect the ground. If the ground connection is not secure, you run a high risk of receiving a serious electric shock, and problems with correct operation may also occur.

5



Direction of operation

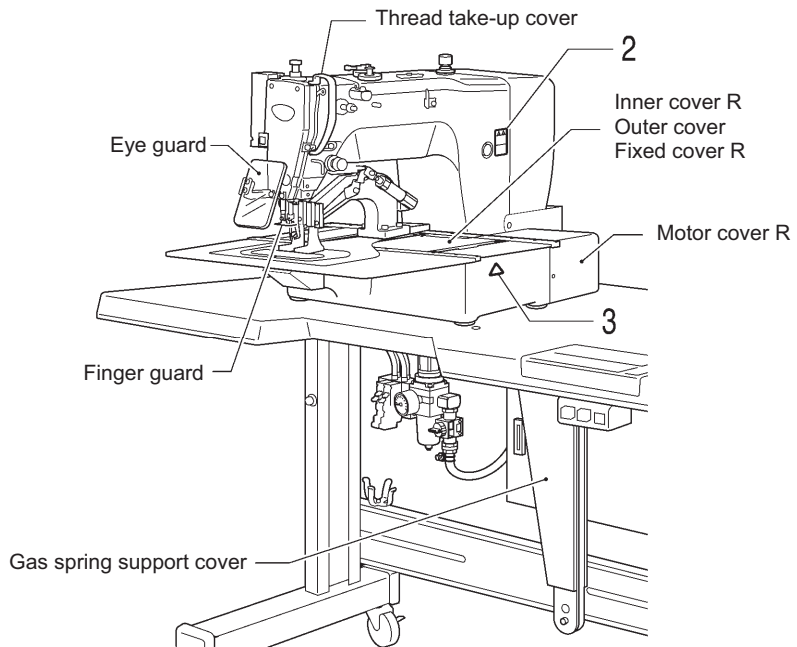
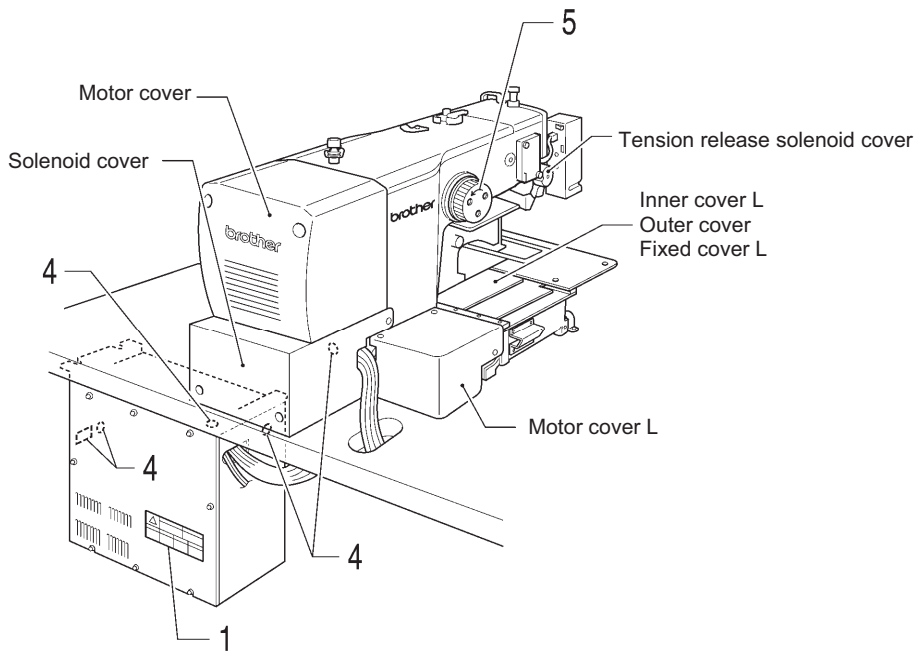

CONTENTS

1. NAMES OF MAJOR PARTS	1	5. USING THE OPERATION PANEL	
2. SPECIFICATIONS	2	(BASIC OPERATIONS)	25
3. INSTALLATION	3	5-1. Name and function of each operation	
3-1. Table processing diagram	3	panel item	25
3-2. Installing the control box.....	4	5-2. Loading sewing data	27
3-3. Installing the oil pan	4	5-3. Setting the program number	27
3-4. Installing the machine head.....	5	5-4. Setting the X-scale and Y-scale	28
3-5. Tilting the sewing machine head	9	5-5. Setting the sewing speed.....	28
3-6. Installing the operation panel.....	9	5-6. Checking the sewing pattern	29
3-7. Installing the pneumatic unit.....	10	5-7. Setting the height of the intermittent	
3-8. Connecting the cords.....	11	presser foot.....	30
3-9. Connecting the ground wire.....	13	6. USING THE OPERATION PANEL	
3-10. Connecting the power cord.....	14	(ADVANCED OPERATIONS).....	31
3-11. Installing the cotton stand.....	14	6-1. List of advanced functions	31
3-12. Installing the eye guard	15	6-2. Setting memory switches.....	32
3-13. Installing the motor cover	16	6-3. List of memory switch settings.....	33
3-14. Lubrication	17	6-4. Using the lower thread counter.....	34
3-15. Installing the machine head fixing bolt	18	6-5. Using the production counter.....	35
4. PREPARATION BEFORE SEWING.....	19	6-6. Setting the split number	36
4-1. Installing the needle.....	19	6-7. Using user programs	37
4-2. Threading the upper thread	19	6-8. Using cycle programs	40
4-3. Foot switch operating method	20	6-9. Direct selection (combination table)	42
4-4. Winding the lower thread.....	21	6-10. X and Y parallel movement	
4-5. Installing the bobbin case	22	of sewing pattern	43
4-6. Thread tension.....	23	6-11. Clearing memory data (reinitialization)	44
4-6-1. Lower thread tension	23	7. USING CF CARDS.....	45
4-6-2. Upper thread tension	23	7-1. Notes on handling CF cards (sold separately)	
4-7. Home position detection	24	45
		7-2. Structure of a CF card folder	45
		7-3. Data read/write mode	46
		7-3-1. Reading all sewing data from the	
		CF card at once	47
		7-3-2. Writing all sewing data to the CF card at	
		once	48

8. SEWING	49	11. TABLE OF ERROR CODES	65
8-1. Sewing	49	12. TROUBLESHOOTING	69
8-2. Using the STOP switch.....	50	13. 7-SEGMENT DISPLAY	73
8-3. Using the thread wiper switch.....	50		
9. CLEANING	51		
9-1. Cleaning the rotary hook	51		
9-2. Cleaning the control box air inlet ports	51		
9-3. Draining the oil.....	52		
9-4. Cleaning the eye guard	52		
9-5. Checking the needle.....	52		
9-6. Lubrication	52		
10. STANDARD ADJUSTMENTS	53		
10-1. Checking the machine head switch.....	53		
10-2. Arm thread guide R	53		
10-3. Thread take-up spring	54		
10-4. Adjusting the needle bar height.....	54		
10-5. Adjusting the needle bar lift amount.....	55		
10-6. Adjusting the needle guard.....	55		
10-7. Adjusting the needle clearance	56		
10-8. Adjusting the inner rotary hook and hook stopper overlap.....	56		
10-9. Rotary hook lubrication amount.....	56		
10-10. Adjusting the position of the movable knife..	57		
10-11. Replacing the movable and fixed knives	59		
10-11-1. Installing the feed plate	60		
10-12. Adjusting the thread wiper	61		
10-13. Intermittent presser foot installation position	61		
10-14. Changing the intermittent stroke	62		
10-15. Adjusting the work clamp lift amount.....	64		
10-16. Adjusting the air pressure.....	64		

1. NAMES OF MAJOR PARTS

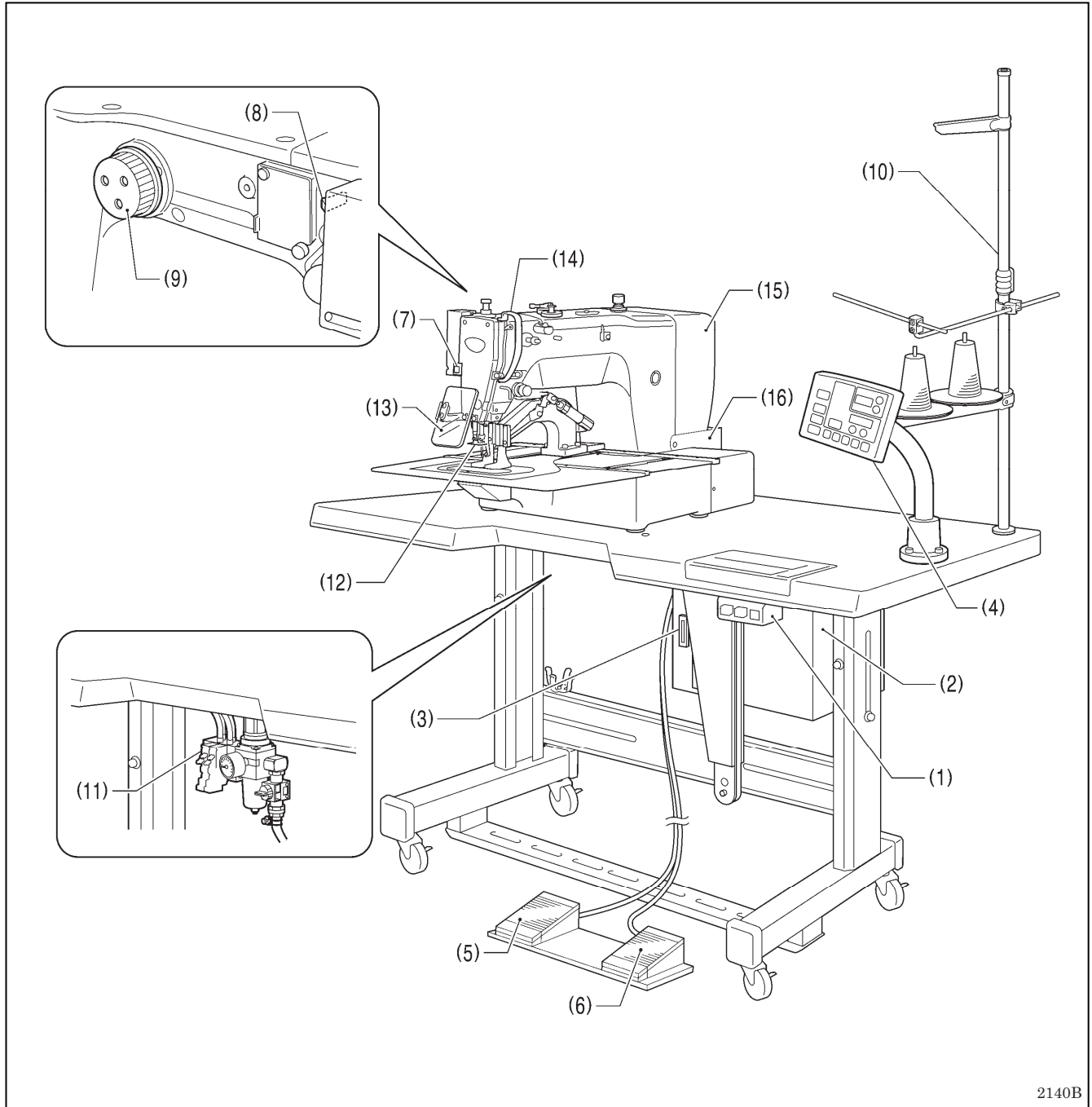

2140B

- (1) Power switch
- (2) Control box
- (3) CF slot
- (4) Operation panel
- (5) Work clamp switch
- (6) Start switch
- (7) STOP switch
- (8) Thread wiper switch
- (9) Pulley
- (10) Cotton stand
- (11) Solenoid valve

- Safety devices:**
- (12) Finger guard
 - (13) Eye guard
 - (14) Thread take-up cover
 - (15) Motor cover
 - (16) Solenoid cover

CF™ is a trademark of SanDisk Corporation.

2. SPECIFICATIONS

BROTHER INDUSTRIES, LTD.

•BAS-326G-01A PS•

1 Heavy-weight materials









2359B

Sewing machine	Lock stitch pattern tacking sewing machine
Stitch formation	Single needle lock stitch
Max. sewing speed	2,700 sti/min
Sewing area (XxY)	Max. 220 x 100 mm
Feed mechanism	Intermittent feed, pulse motor drive
Stitch length	0.05 – 12.7 mm
No. of stitches	500,000-stitch internal memory (*)
Maximum no. of stitches	20,000 stitches (per program)
No. of sewing data items that can be stored	Internal memory: 512 (*), CF card: 900
Work clamp lift method	Pneumatic method
Work clamp height	Max. 30 mm
Intermittent presser foot lift amount	19.5 mm
Intermittent stroke	2 – 4.5 mm, 4.5 – 10 mm or 0 (Default setting 3 mm)
Hook	Double-capacity rotary hook
Wiper device	Standard equipment
Thread trimmer	Standard equipment
Data storage method	Internal memory (Flash memory), CF card (32 MB – 2 GB) [Option] 3.5 floppy disk 2HD/1.44MB, 2DD
User programs	50
Cycle programs	9
Motor	550 W AC servo motor
Weights	Machine head approx. 90 kg, operation panel approx. 0.6 kg Control box 14.2 – 16.2 kg (Differs depending on destination)
Power supply	Single-phase 100 V/220 V, Three-phase 200 V/220 V/380 V/400 V 400 VA
Air pressure	0.5 MPa 1.8 l/min.

* The number of data items and stitches that can be stored will vary depending on the number of stitches in each program.

3. INSTALLATION

⚠ CAUTION

-  Machine installation should only be carried out by a qualified technician.
-  Contact your Brother dealer or a qualified electrician for any electrical work that may need to be done.
-  The sewing machine head weighs approximately 90kg. The installation should be carried out by two or more people.
-  Do not connect the power cord until installation is complete.
If the foot switch is depressed by mistake, the sewing machine might start operating and injury could result.
-  Hold the machine head with both hands when tilting it back or returning it to its original position.
Furthermore, do not apply excessive force when tilting back the machine head. The sewing machine may become unbalanced and fall down, and serious injury or damage to the sewing machine may result.
-  All cords should be secured at least 25 mm away from any moving parts. Furthermore, do not excessively bend the cords or secure them too firmly staples, otherwise there is the danger that fire or electric shocks could occur.
- 
-  Be sure to connect the ground. If the ground connection is not secure, you run a high risk of receiving a serious electric shock, and problems with correct operation may also occur.
-  Install the safety covers to the machine head and motor.

3-1. Table processing diagram

- The thickness of the table should be at least 40 mm, and it should be strong enough to bear the weight and vibration of the sewing machine.
- If the distance A between the insides of the legs is less than 740 mm, move the control box installation position to the left (B = 261mm).
- Check that the control box is at least 10 mm away from the leg. If the control box and the leg are too close together, it may result in incorrect sewing machine operation.

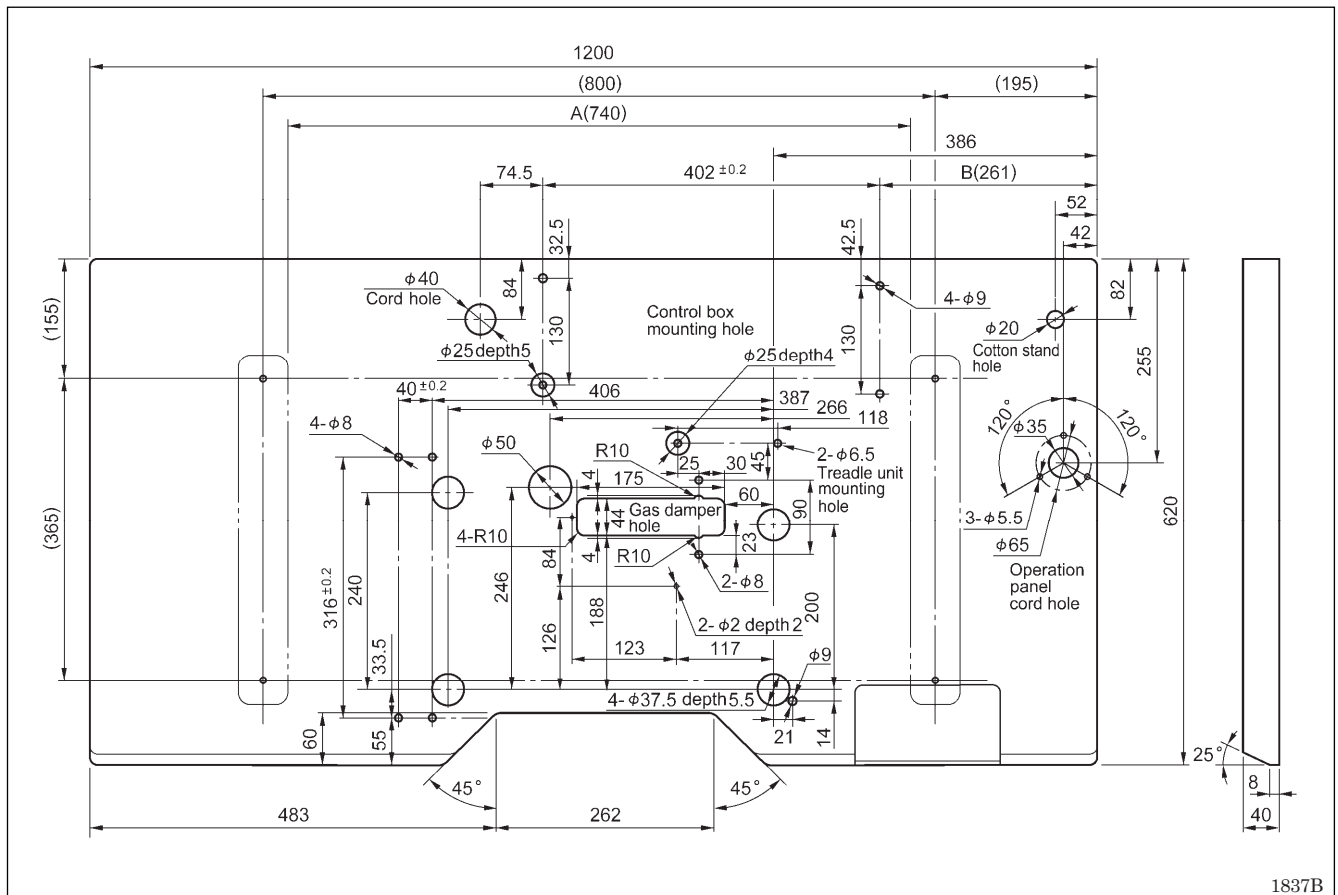

3-2. Installing the control box

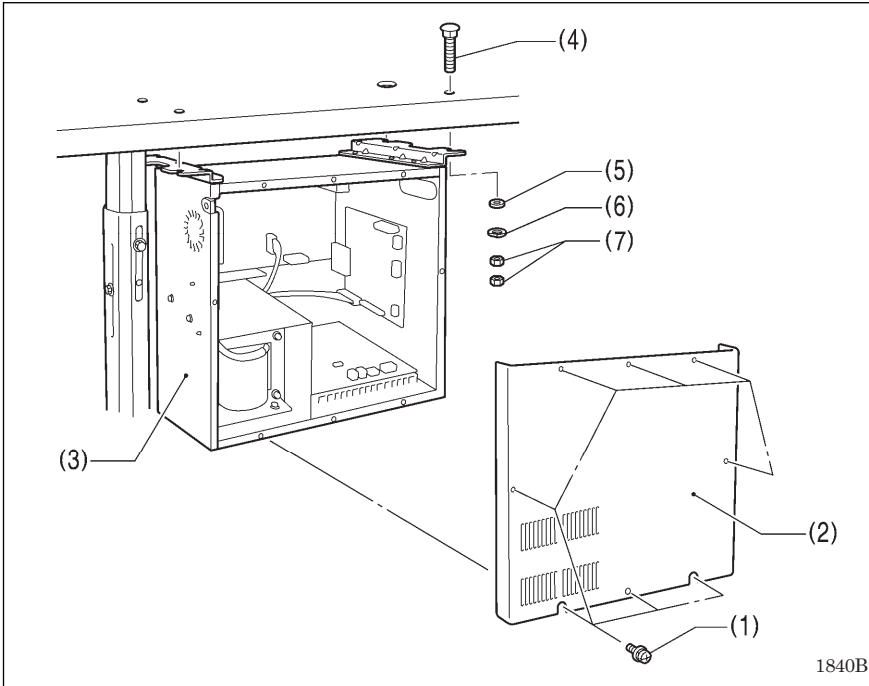

Remove the eight screws (1), and then remove the control box cover (2).

- (3) Control box
- (4) Bolts [4 pcs.]
- (5) Plain washers [4 pcs.]
- (6) Spring washers [4 pcs.]
- (7) Nuts [8 pcs.]

1840B

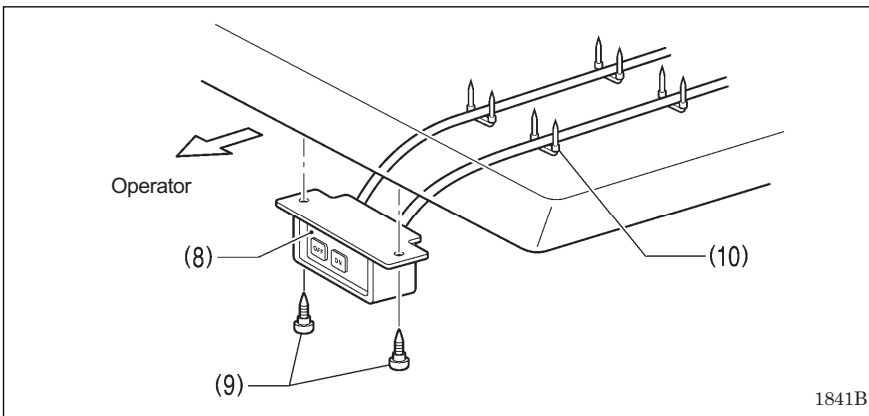

- (8) Power switch
- (9) Wood screws [2 pcs.]
- (10) Staples [4 pcs.]

1841B

3-3. Installing the oil pan

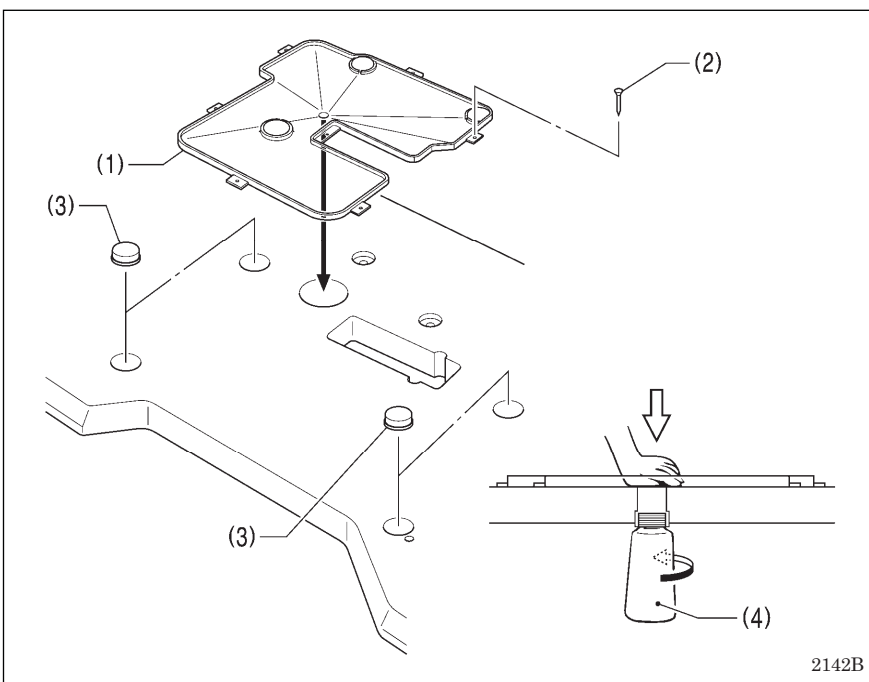

- (1) Oil pan
- (2) Nails [7 pcs.]
- (3) Rubber cushions [4 pcs.]
- (4) Waste oil tank

2142B

3-4. Installing the machine head

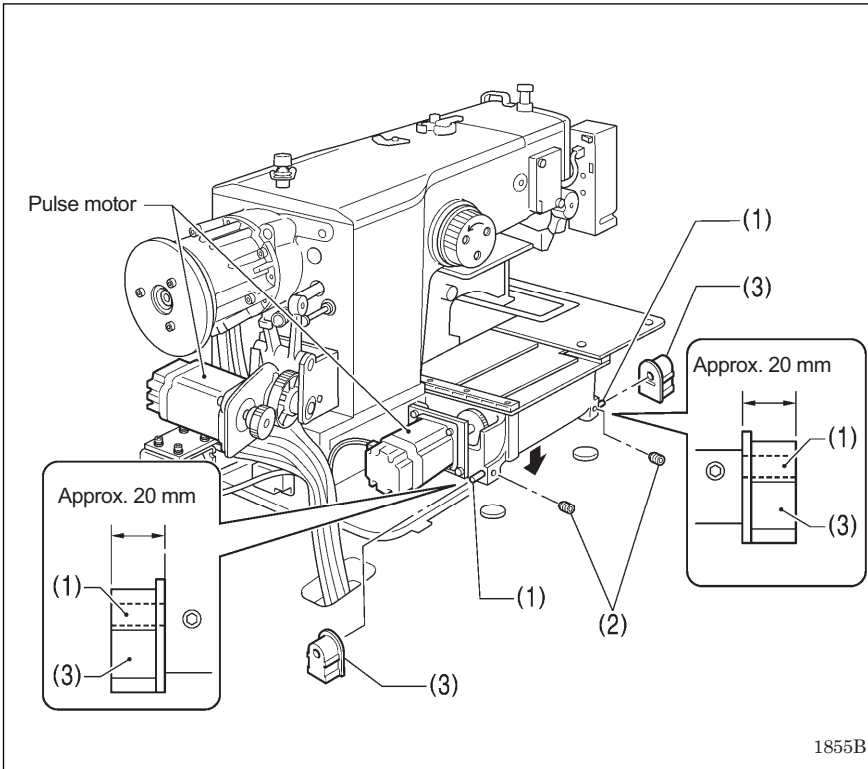

- (1) Pins [2 pcs.]
- (2) Set screws [2 pcs.]
- (3) Hinge rubber assemblies [2 pcs.]

Place the machine head gently on top of the oil pan and the rubber cushions.

NOTE:

- Be careful not to get the cords clamped between the machine head and the oil pan.
- When holding the machine head, do not hold it by the pulse motor. This may cause problems with operation of the pulse motor.

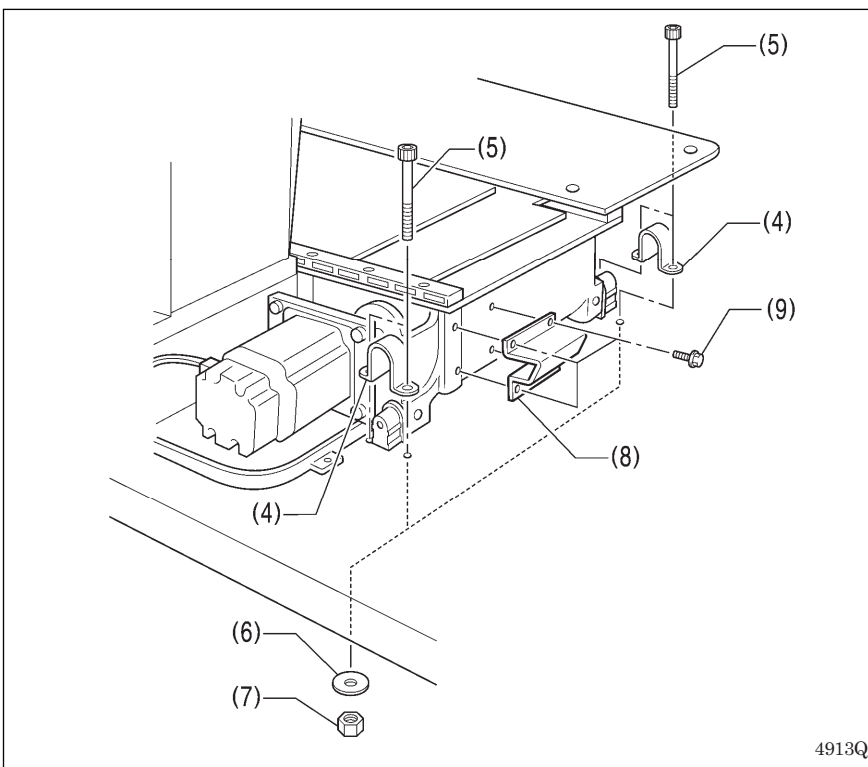

- (4) Hinge holders [2 pcs.]
- (5) Bolts [4 pcs.]
- (6) Plain washers [4 pcs.]
- (7) Nuts [4 pcs.]
- (8) Head rest
- (9) Bolts with washer [4 pcs.]

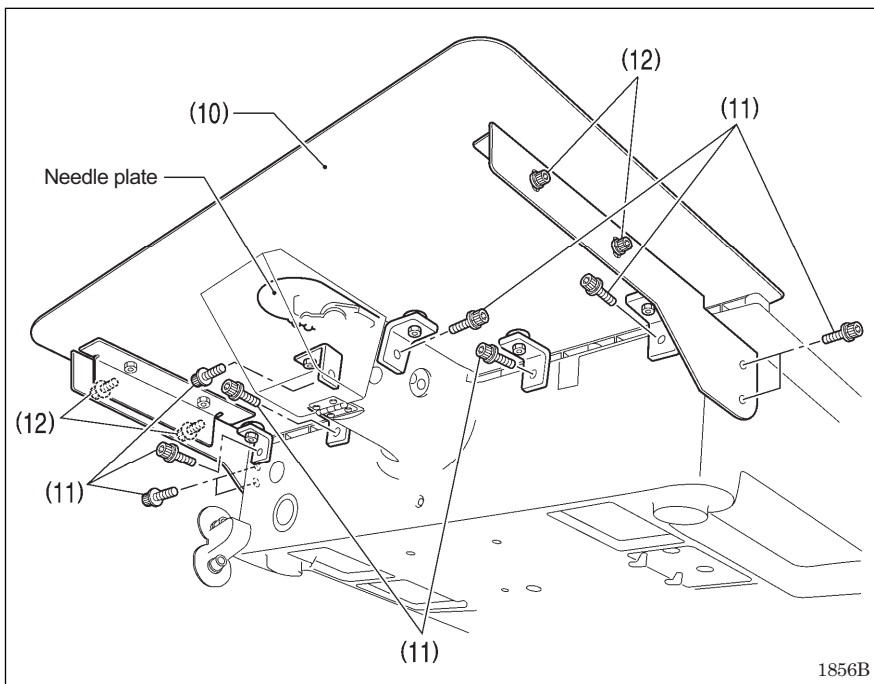

- (10) Auxiliary plate
- (11) Bolts with washer [10 pcs.]

Loosen the bolts with washer (12) and adjust so that the auxiliary plate (10) and the needle plate are at the same height.

NOTE:

Install the auxiliary plate so that it is horizontal.

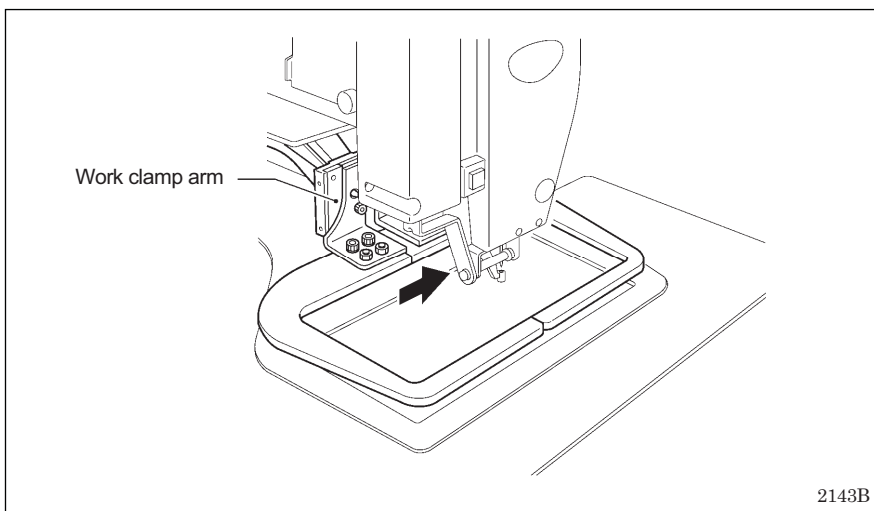

Move the work clamp arm all the way to the right when looking from the front of the sewing machine (the direction of the arrow in the illustration), and then gently tilt back the machine head.

NOTE:

Two or more people should tilt back the machine head, and it should be tilted gently while being held with both hands.

3. INSTALLATION

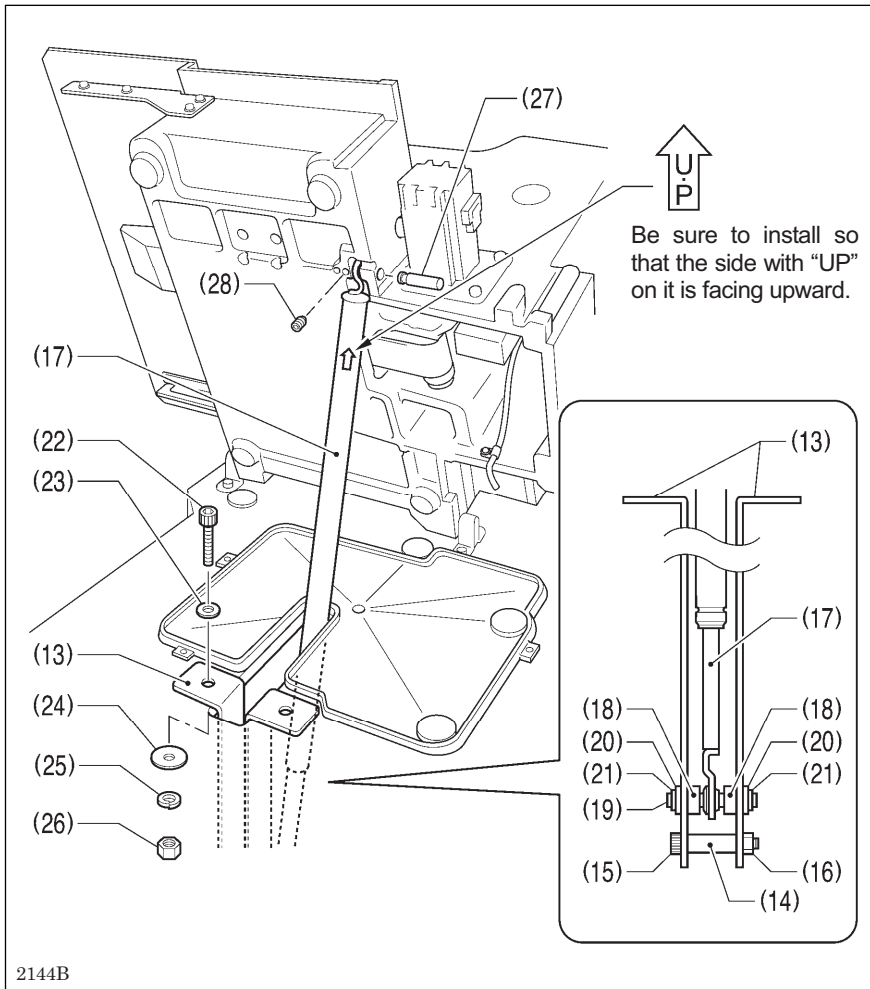

- (13) Gas spring holders [2 pcs.]
- (14) Spacer
- (15) Bolt
- (16) Nut
- (17) Gas spring
- (18) Shaft collars [2 pcs.]
- (19) Gas spring shaft D
- (20) Plain washers [2 pcs.]
- (21) Retaining rings E [2 pcs.]
- (22) Bolts [2 pcs.]
- (23) Plain washers (medium) [2 pcs.]
- (24) Plain washers (large) [2 pcs.]
- (25) Spring washers [2 pcs.]
- (26) Nuts [2 pcs.]
- (27) Gas spring shaft U
- (28) Set screw

2144B

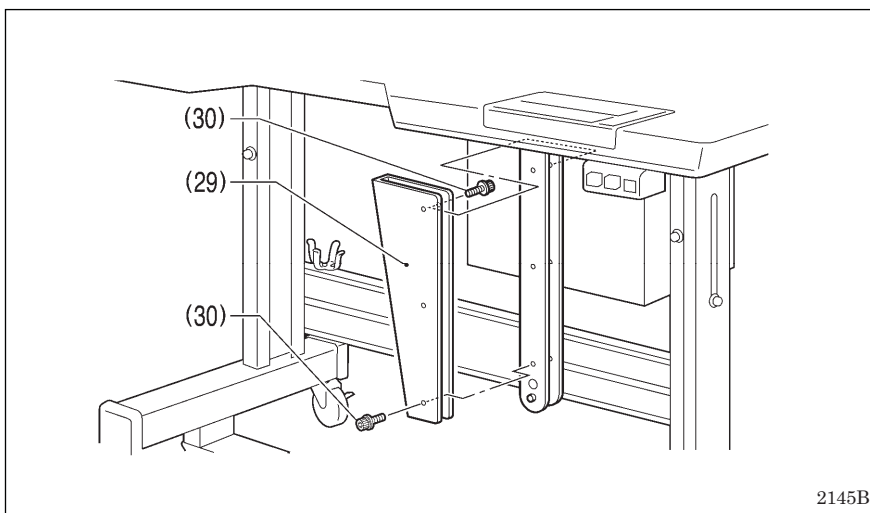

- (29) Gas spring support cover
- (30) Bolts with washer [6 pcs.]

2145B

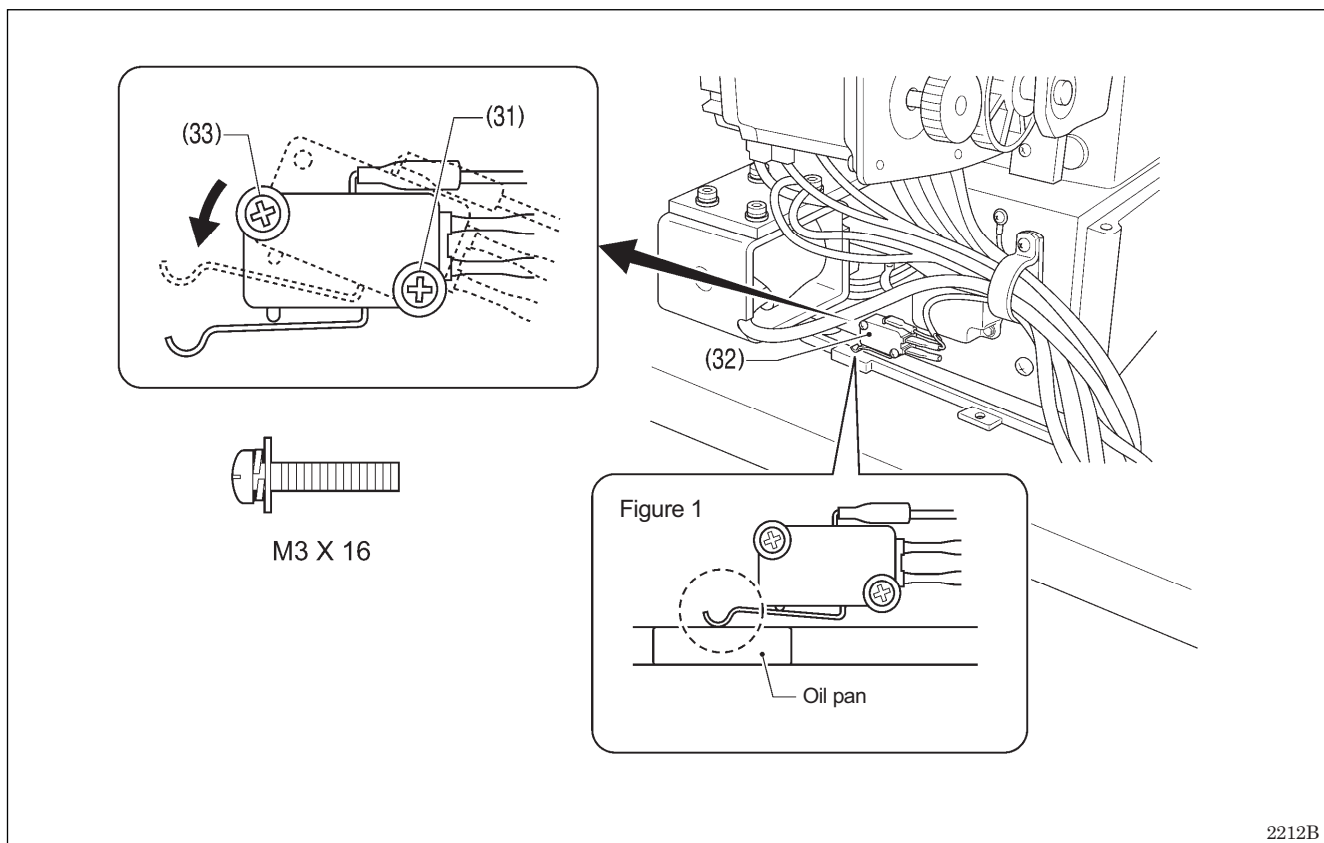

- Gently return the machine head to its original position.
- Loosen the screw (31). Move the machine head switch (32) to the position shown in the illustration, and then secure the machine head switch (32) with the screw (31) and the accessory M3x16 screw (33).
- Check that the machine head switch (32) is turned on as shown in figure 1.

NOTE:

If the machine head switch is not turned on, errors "E050", "E051" and "E055" will be generated.

3-5. Tilting the sewing machine head

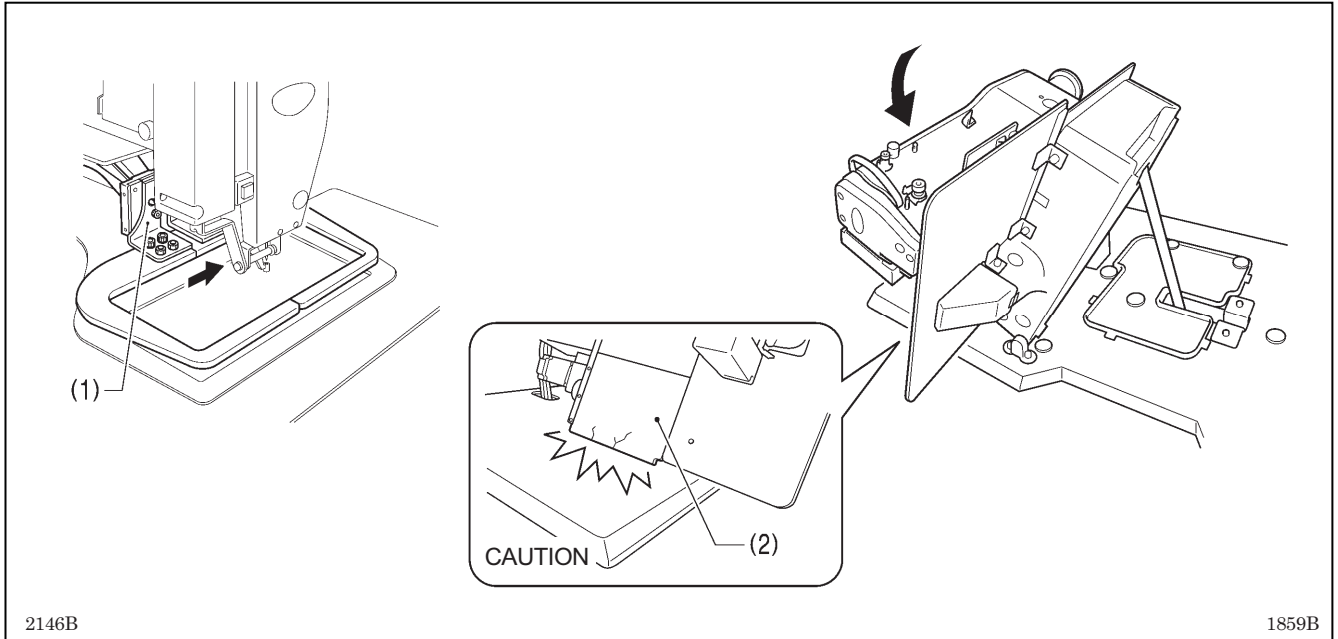

1. Move the presser arm assembly (1) as far as it will go in the direction of the arrow in the illustration (to the right when looking from the front of the sewing machine).
2. Stand at the left side of the table, and gently tilt the machine head towards you.

NOTE:

Always be sure to move the work clamp arm all the way to the right before tilting back the machine head. If you try to tilt back the machine head while the work clamp arm is still on the left side, it may damage the outer cover L (2).

3-6. Installing the operation panel

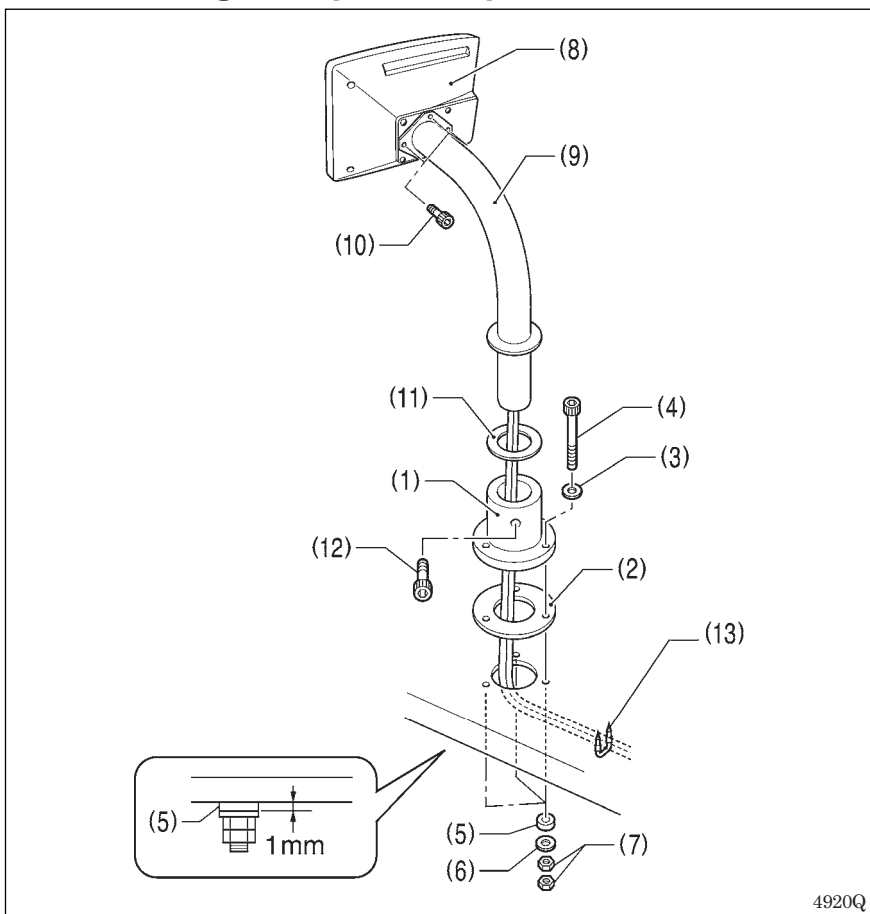

- (1) Operation panel base
- (2) Cushion A
- (3) Plain washers (medium) [3 pcs.]
- (4) Bolts [3 pcs.]
- (5) Cushions B [3 pcs.]
- (6) Plain washers (large) [3 pcs.]
- (7) Nuts [6 pcs.]

Tighten until the thickness of cushion B (5) is about 1 mm.

- (8) Operation panel
- (9) Operation panel stand
- (10) Bolts [3 pcs.]
- (11) Rubber seat
- (12) Bolt

- Pass the panel cord through the operation panel stand (9) and the rubber seat (11).
- Fit the operation panel stand (9) into the operation panel base (1), and then secure it with the bolt (12).
- Pass the panel cord through the hole in the table, and then insert it into the control box through the hole in the side of the control box.

- (13) Staples [3 pcs.]

3-7. Installing the pneumatic unit

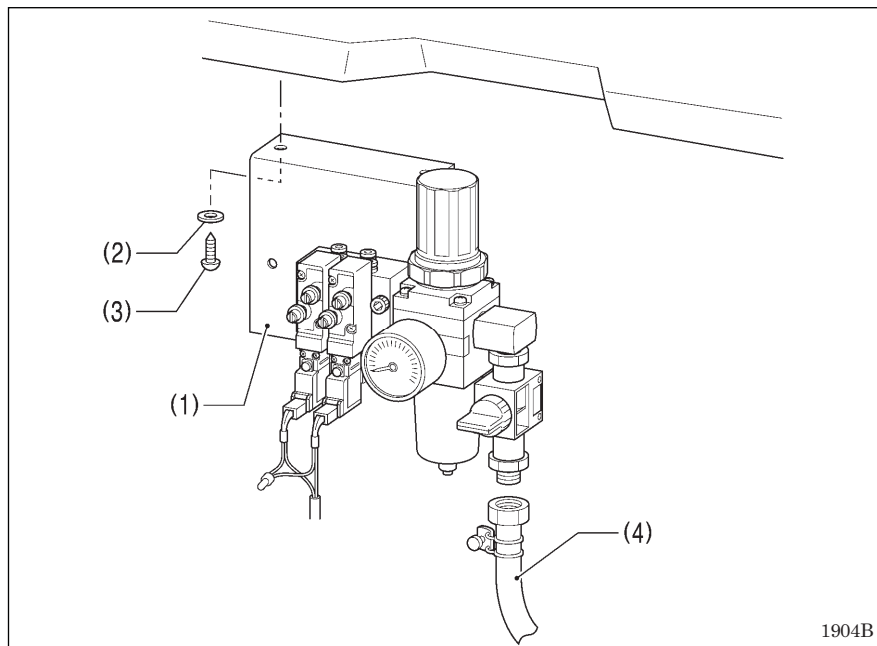

Install underneath the work table.

- (1) Solenoid valve assembly
- (2) Washers [2 pcs.]
- (3) Wood screws [2 pcs.]
- (4) Rubber hose

After installing the pneumatic unit, adjust the air pressure.
(Refer to "10-16. Adjusting the air pressure".)

NOTE:

Make sure that the pneumatic unit does not touch the control box or the work table leg.

Connect each air tube to the position with the corresponding number.

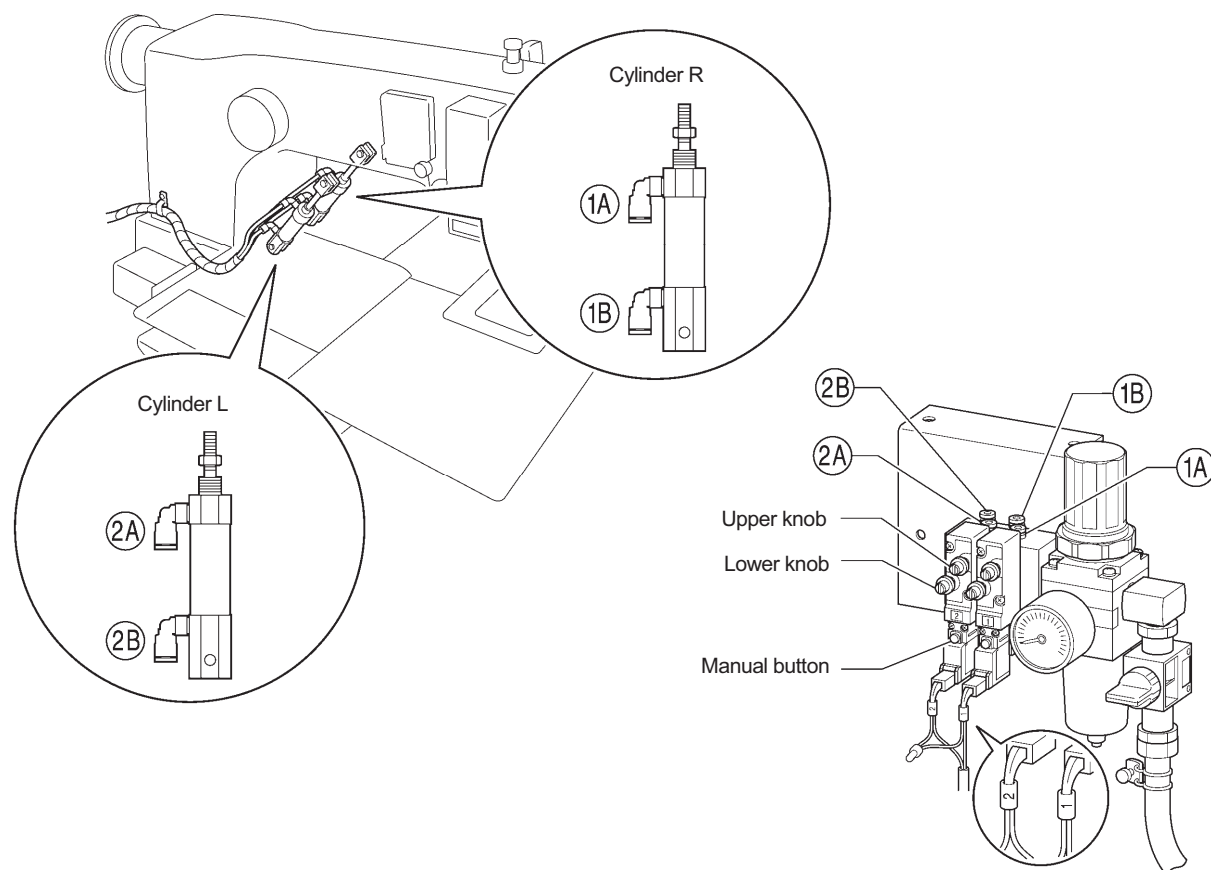

<Adjusting the speed controller>

You can use the valve knobs to adjust the lifting and lowering speeds.

The valve knobs should be adjusted so that the left and right sides of the work clamp operate at the same speed.

- When the upper knob is tightened, the lifting speed becomes slower. When it is loosened, the lifting speed becomes faster.
- When the lower knob is tightened, the lowering speed becomes slower. When it is loosened, the lowering speed becomes faster.

You can operate the work clamp while the power is turned off by pressing the manual button.

5220Q 1905B

3-8. Connecting the cords

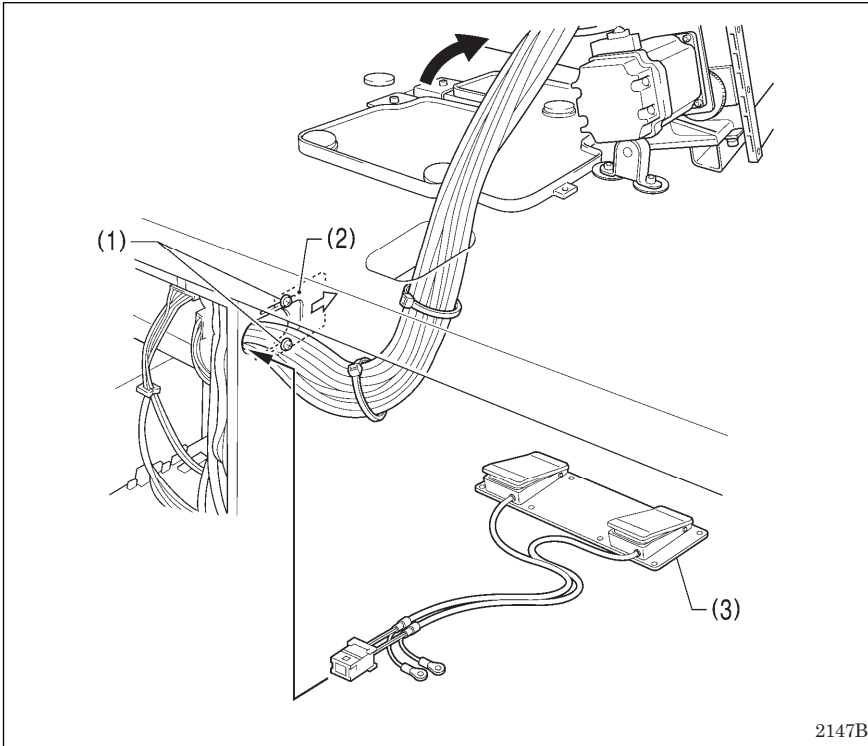

1. Gently tilt back the machine head.
2. Pass the cord bundle through the hole in the work table.
3. Loosen the two screws (1), and then open the cord presser plate (2) in the direction of the arrow and pass the cord bundle through the opening together with the following cords.
 - Two-pedal foot switch (3)
 - Operation panel (Do not pass the ground wires through the hole.)
 - Solenoid valve assembly
4. Securely connect the connectors as indicated in the table below.

NOTE:

- Check that the connector is facing the correct way, and then insert it firmly until it locks into place.
- Secure the cables with cable ties and cord clamps, while being careful not to pull on the connector.

2147B

<Main P.C. board>

NOTE:

- Check that the connector is facing the correct way, and then insert it firmly until it locks into place.
- Secure the cables with cable ties and cord clamps, while being careful not to pull on the connector.

*1: Be sure to make the ground connection.
(Refer to "3-9. Connecting the ground wire".)

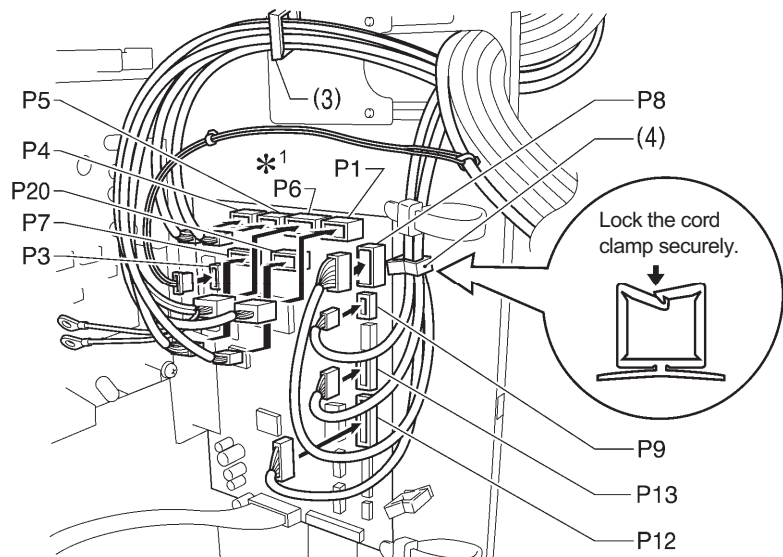

Connector	Connection location on main P.C. board	Cord clamp
X pulse motor encoder 5-pin white	P20 (X-ENC)	(3)
Y pulse motor encoder 5-pin blue	P4 (Y-ENC)	(3)
Work clamp pulse motor encoder 5-pin black	P5 (P-ENC)	(3)
Foot switch 10-pin	P6 (FOOT)	(3)
Operation panel 8-pin	P1 (PANEL)	(3)
Machine head switch 3-pin	P9 (HEAD-SW)	(4)
Home position sensor assembly 12-pin	P8 (SENSOR1)	(4)
STOP switch 6-pin	P13 (HEAD)	(4)
Valve harness 12-pin	P12 (AIR1)	(4)
Programmer relay harness 8-pin	P7 (PRG)	(3)
Solenoid selection harness 4-pin*2	P3 (CUTTER)	—

*2: The 4-pin solenoid selection harness may not be used for some versions of tension release solenoid.

2148B

<Power supply motor P.C. board>

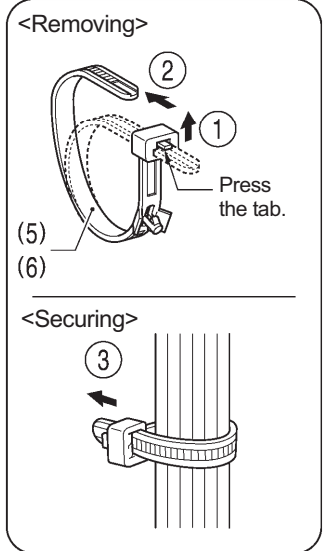
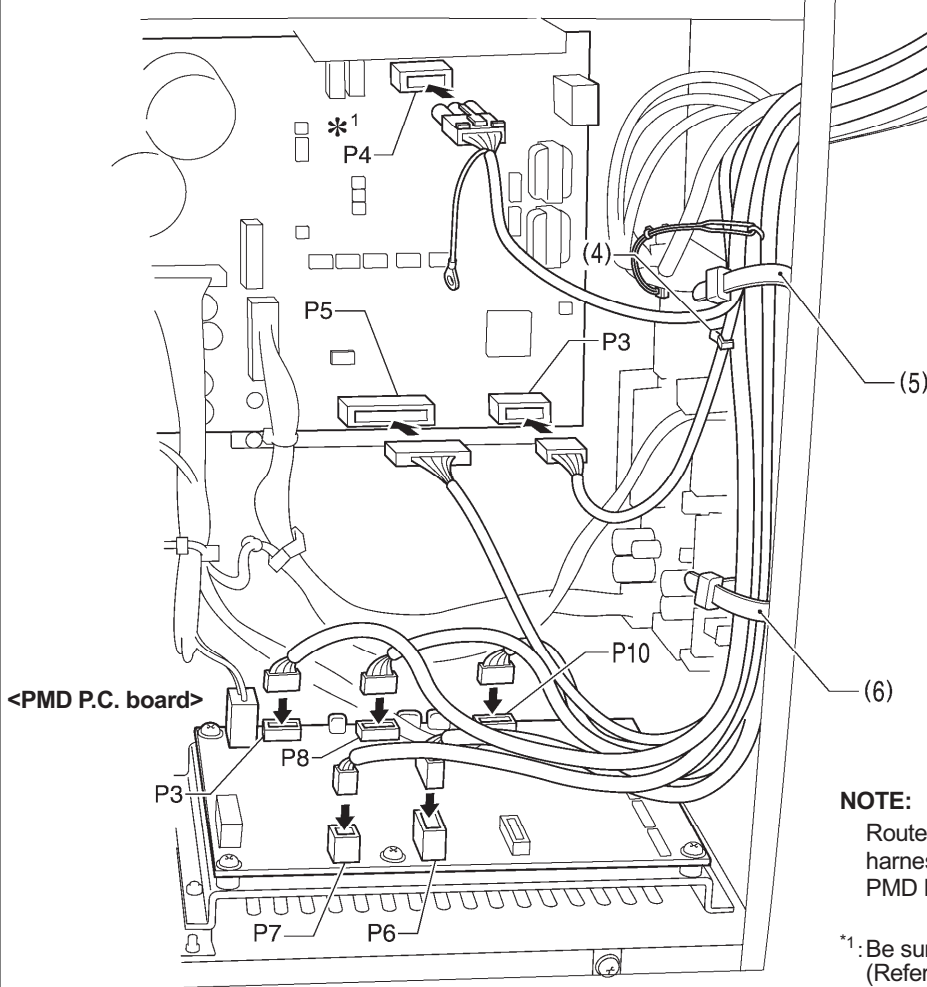

NOTE:

Route the X, Y and work clamp pulse motor harnesses so that they do not touch the PMD P.C.

*1: Be sure to make the ground connection. (Refer to "3-9. Connecting the ground wire".)

Connector	Connection location on power supply motor P.C. board	Cord clamp/cable tie
Machine head memory 7-pin	P3 (HEAD-M)	(4)
Upper shaft motor 3-pin	P4 (UVW)	(5)
Synchronizer 14-pin	P5 (SYNC)	(5), (6)
Connector	Connection location on PMD P.C. board	Cable tie
Work clamp pulse motor 4-pin black	P3 (PPM)	(5), (6)
Thread trimmer solenoid 6-pin	P6 (SOL1)	(5), (6)
Tension release solenoid 4-pin	P7 (SOL2)	(5), (6)
Y pulse motor 4-pin blue	P8 (YPM)	(5), (6)
X pulse motor 4-pin white	P10 (XPM)	(5), (6)

1843B

(Continued on next page)

3. INSTALLATION

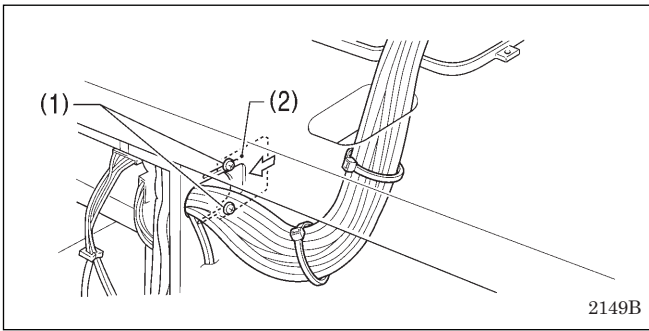

5. Close the cord presser plate (2) in the direction of the left arrow, and secure it by tightening the two screws (1).

Note: Close the cord presser plate (2) securely so that no foreign objects, insects or small animals can get inside the control box.

6. Check that the cords do not get pulled, and then gently return the machine head to its original position.

3-9. Connecting the ground wire

CAUTION



Be sure to connect the ground. If the ground connection is not secure, you run a high risk of receiving a serious electric shock, and problems with correct operation may also occur.

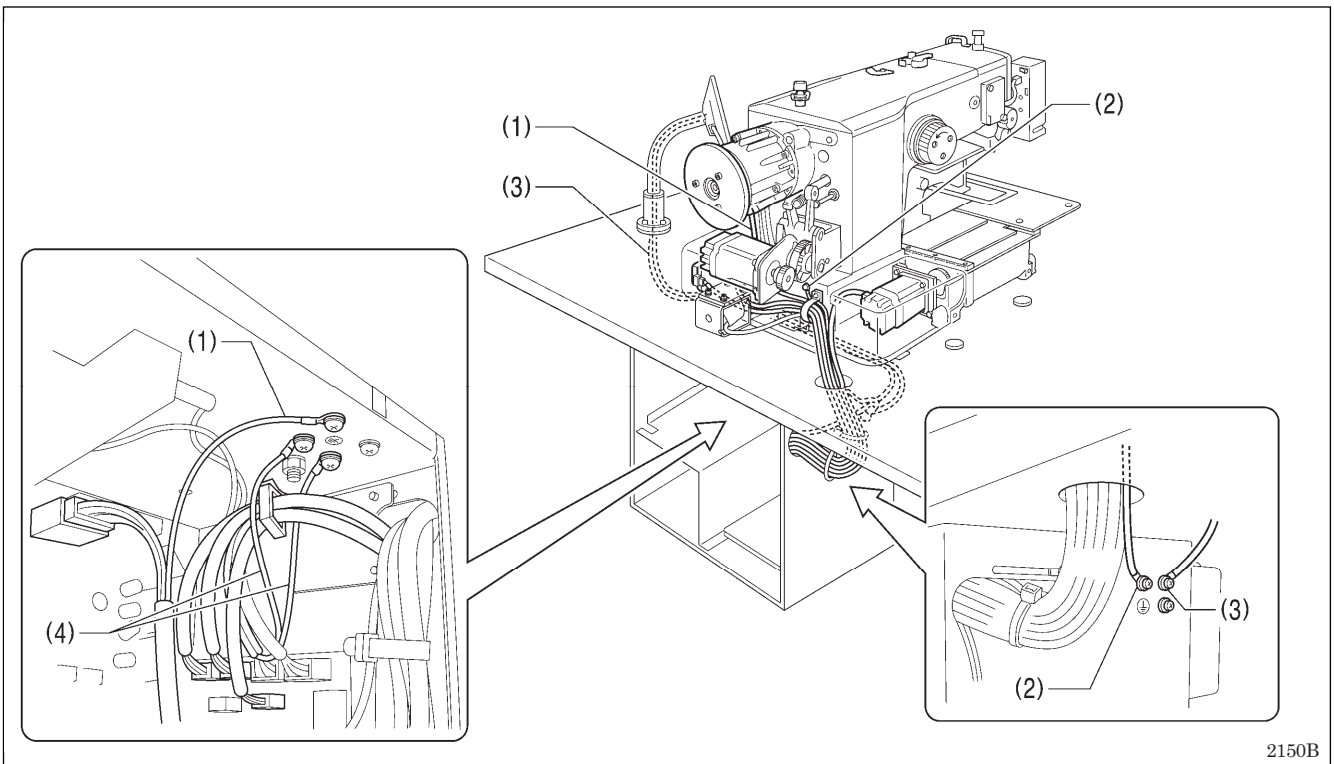

- (1) Ground wire from upper shaft motor harness
- (2) Ground wire from the machine head
- (3) Ground wire from operation panel
- (4) Ground wires from two-pedal foot switch harnesses (2 wires)

• Tighten the control box cover with the eight screws. Check that the cords are not clamped by the cover at this time.

NOTE: Make sure that the ground connections are secure in order to ensure safety.

3-10. Connecting the power cord

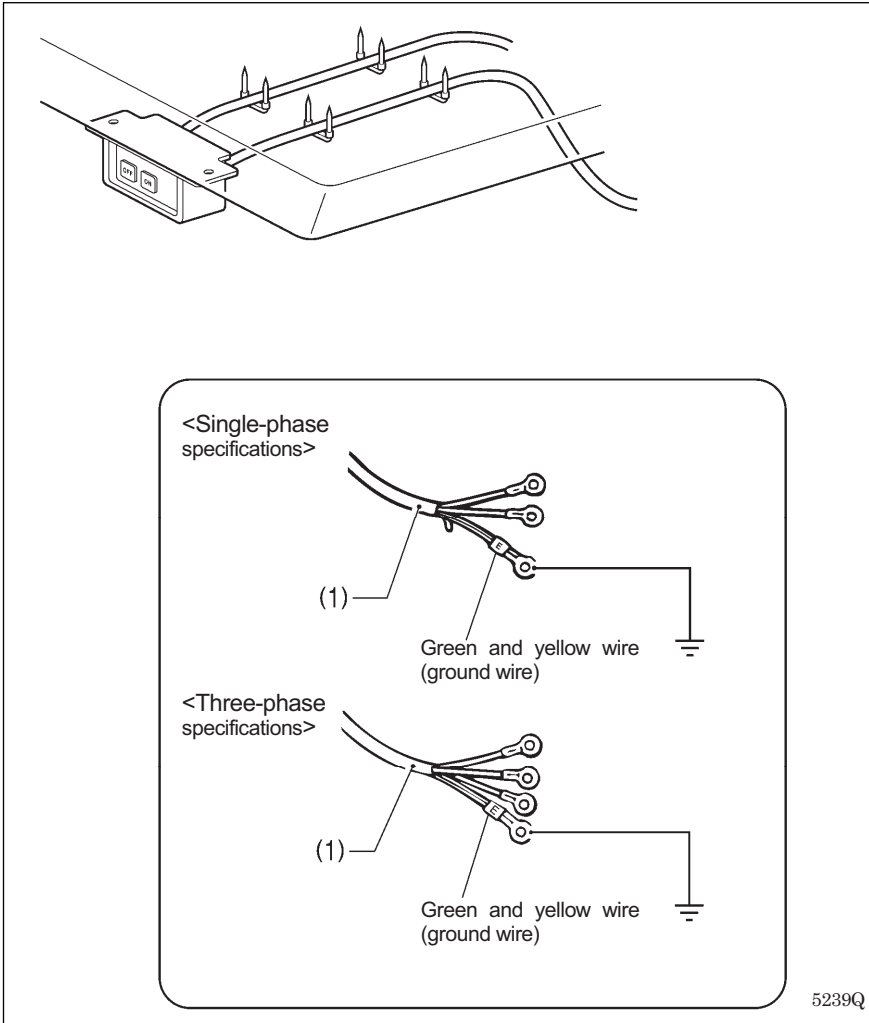

1. Attach an appropriate plug to the power cord (1). (The green and yellow wire is the ground wire.)
2. Insert the plug into a properly-grounded AC power supply.

* The inside of the control box uses single-phase power.

NOTE:

Do not use an extension cord. If this is not observed, it may cause problems with correct operation.

3-11. Installing the cotton stand

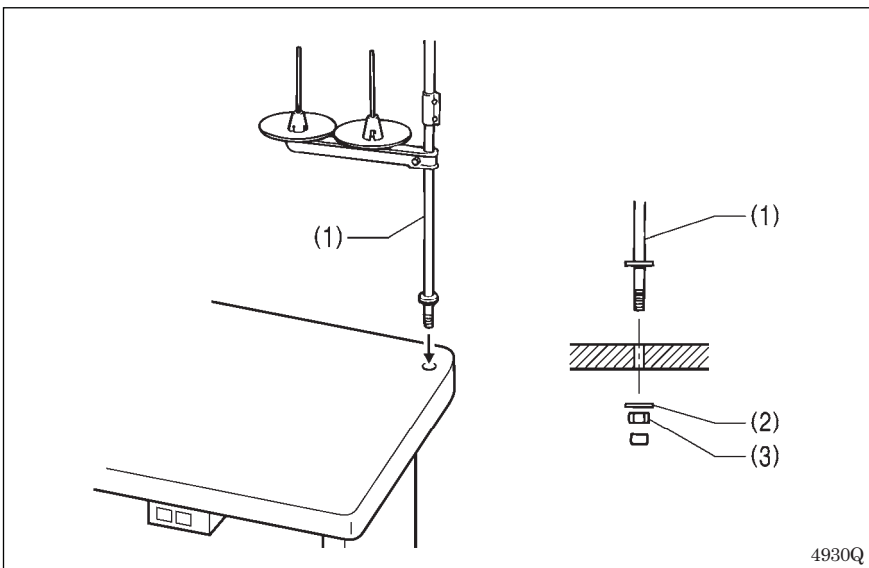

3-12. Installing the eye guard

⚠ CAUTION



Attach all safety devices before using the sewing machine.
If the machine is used without these devices attached, injury may result.

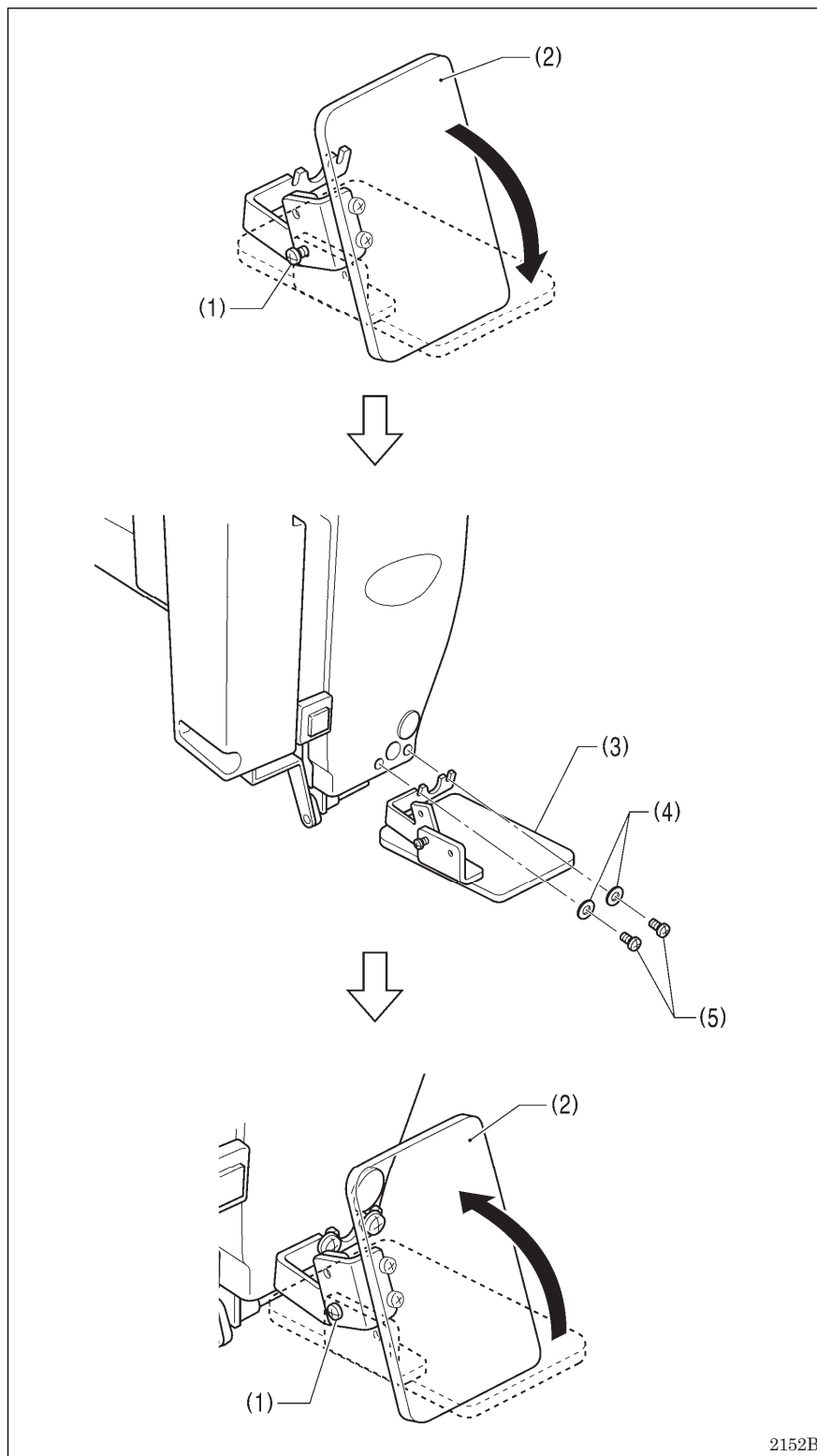

- (1) Screw (loosen)
- (2) Eye guard (tilt forward)
- (3) Eye guard assembly
- (4) Plain washers [2 pcs.]
- (5) Screws [2 pcs.]

After installing the eye guard assembly (3), return the eye guard (2) to its original angle, and then tighten the screw (1) to secure it in place.

2152B

3-13. Installing the motor cover

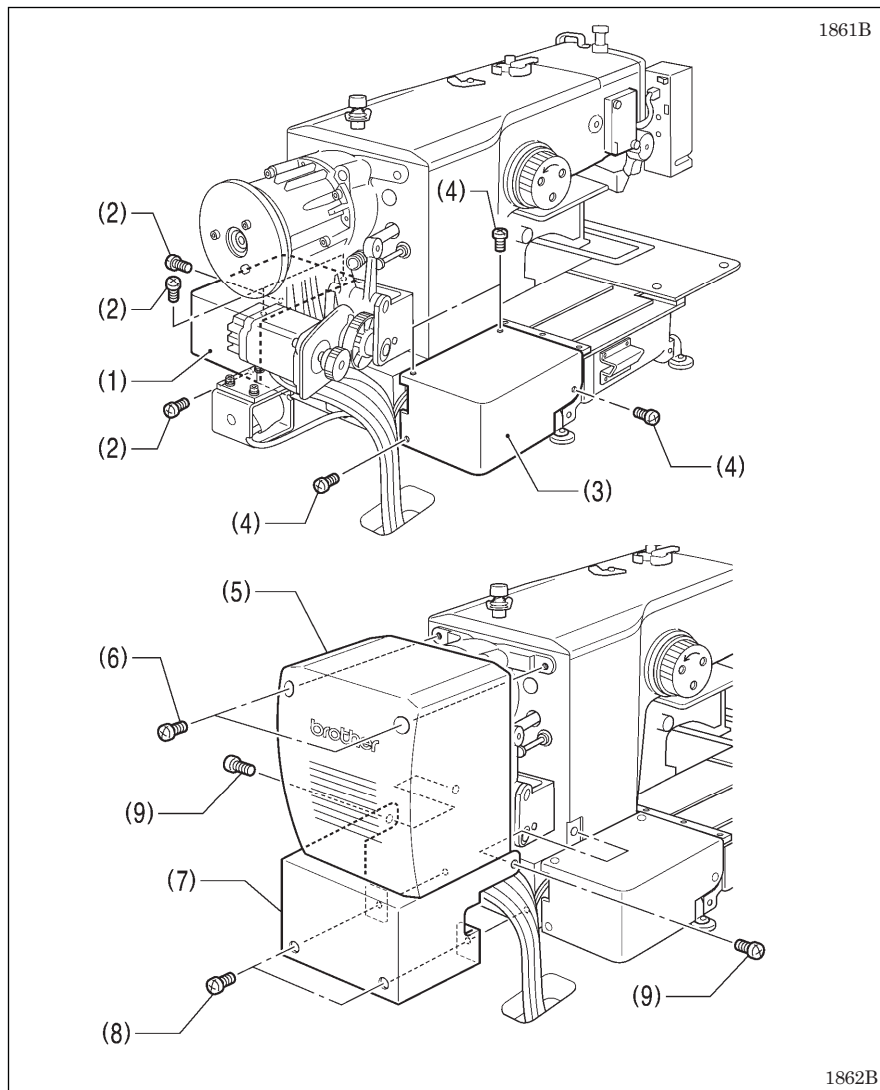

- (1) Motor cover R
- (2) Screws [4 pcs.]
- (3) Motor cover L
- (4) Screws [4 pcs.]
- (5) Motor cover
- (6) Screws [2 pcs.]
- (7) Solenoid cover
- (8) Screws [2 pcs.]
- (9) Screws [2 pcs.]

NOTE:

Be careful not to clamp the cords when installing the motor cover and the solenoid cover.

3-14. Lubrication

! CAUTION



Do not connect the power cord until lubrication is complete.
If the foot switch is depressed by mistake, the sewing machine might start operating and injury could result.



Be sure to wear protective goggles and gloves when handling the lubricating oil and grease, so that they do not get into your eyes or onto your skin. If the oil and grease get into your eyes or onto your skin, inflammation can result. Furthermore, do not drink or eat the lubricating oil or grease. They may cause diarrhea or vomiting. Keep the oil out of the reach of children.

The sewing machine should always be lubricated and the oil supply replenished before it is used for the first time, and also after long periods of non-use.

Use only the lubricating oil <Nippon Oil Corporation Sewing Lube 10N; VG10> specified by Brother.

* If this type of lubricating oil is difficult to obtain, the recommended oil to use is <Exxon Mobil Esstotex SM10; VG10>.

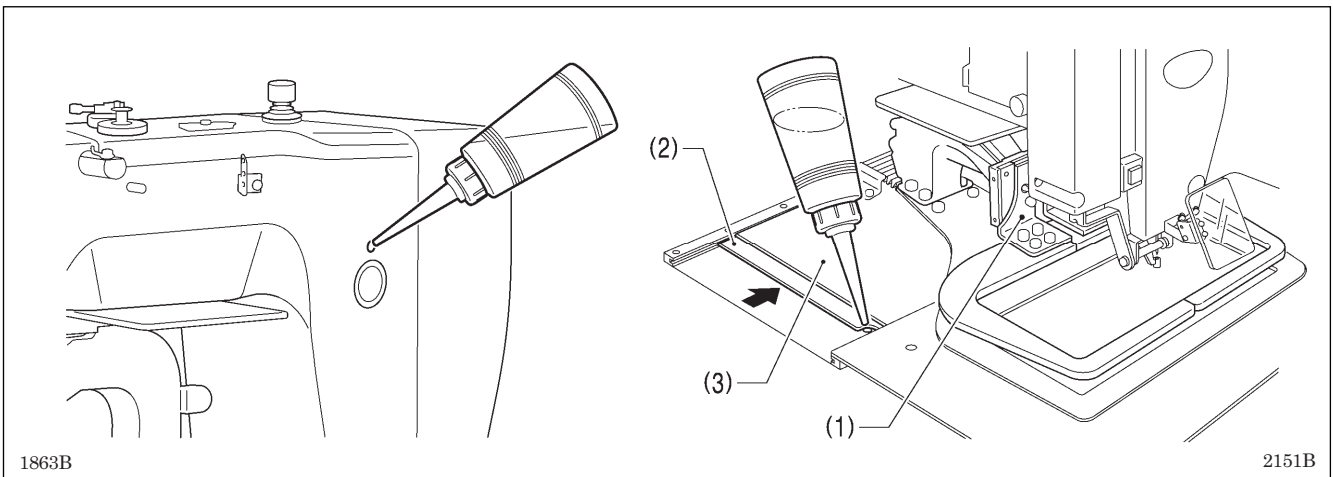

1. Fill the arm-side oil tank with oil.
2. Move the work clamp arm (1) as far as it will go to the right when looking from the front of the sewing machine, and then slide the outer cover L (2) into the inner cover L (3) so that the lubrication hole in the bed is visible. Pour oil into the bed side oil tank through this hole.

NOTE:

Be sure to fill the machine with oil when the oil level is down to about one-third full in the oil sight glass. If the oil drops below the one-third level, there is the danger that the machine may seize during operation.

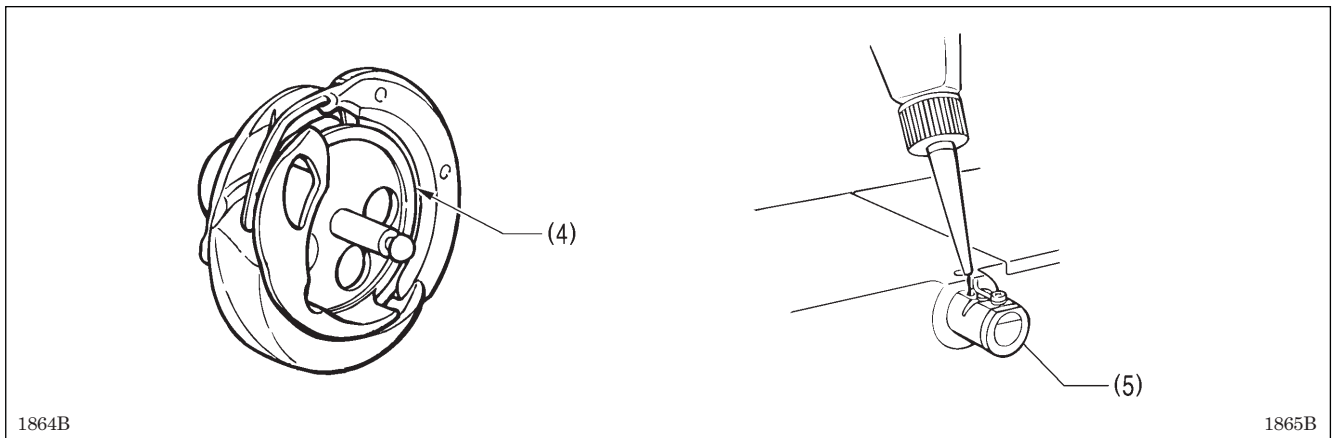

3. Remove the bobbin case and add 2-3 drops of oil to the rotary hook race (4).
4. If using the needle cooler (5), fill it with silicon oil (100 mm²/s).

3-15. Installing the machine head fixing bolt

When transporting the sewing machine, secure the machine head to the table with the machine head fixing bolt.

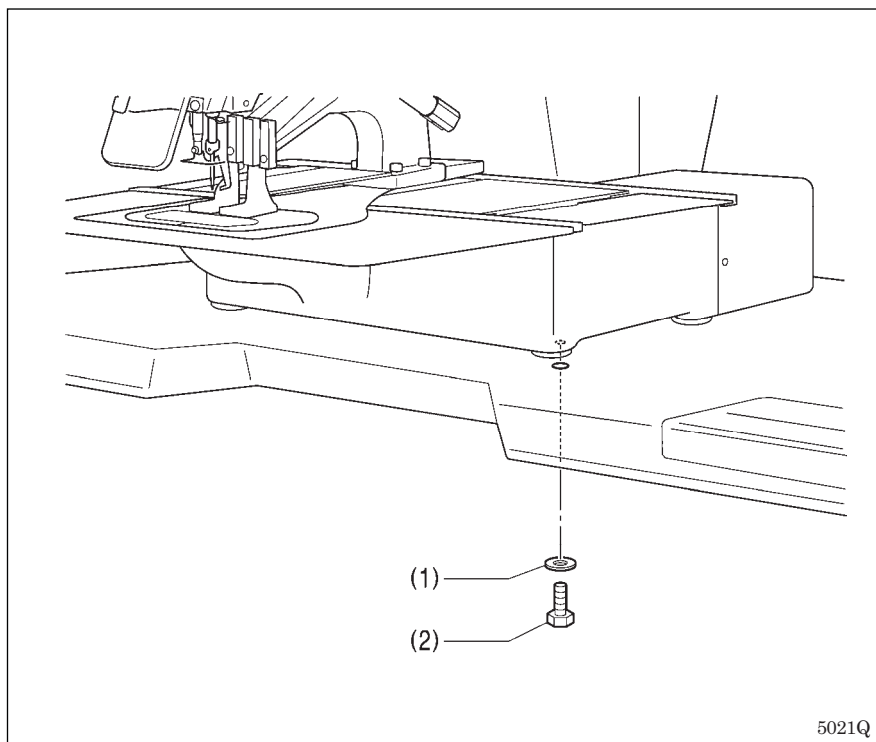

- (1) Plain washer
- (2) Machine head fixing bolt

NOTE:

When operating the sewing machine, remove the machine head fixing bolt.

4. PREPARATION BEFORE SEWING

4-1. Installing the needle

⚠ CAUTION



Turn off the power switch before installing the needle.

If the foot switch is depressed by mistake, the sewing machine might start operating and injury could result.

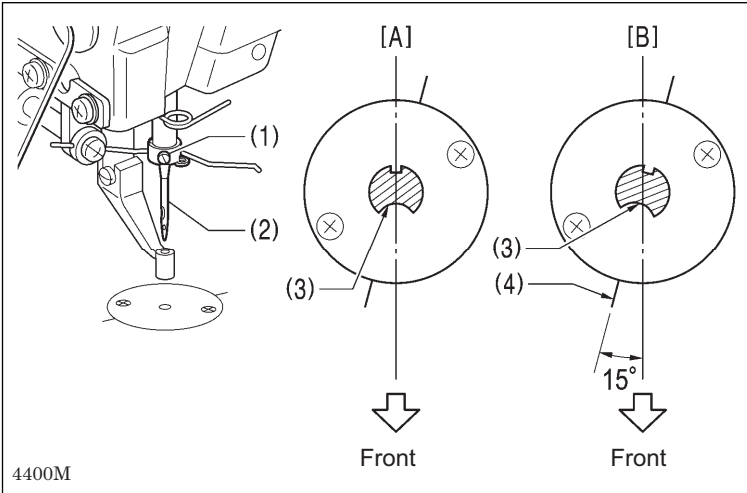

1. Loosen the set screw (1).
2. Insert the needle (2) as far as it will go with the hollow (3) facing to the front, and then securely tighten the set screw (1). [Figure A]

<If hitch stitches appear in one direction during square sewing>

1. Loosen the set screw (1).
2. Insert the needle (2) as far as it will go so with the hollow (3) facing to the front and so that its angle matches the angle of reference line (4), and then securely tighten the set screw (1). [Figure B]

* If the installation angle of the needle has been changed, be sure to readjust the needle clearance. (Refer to "10-7. Adjusting the needle clearance".)

4-2. Threading the upper thread

Thread the upper thread correctly as shown in the illustration below.

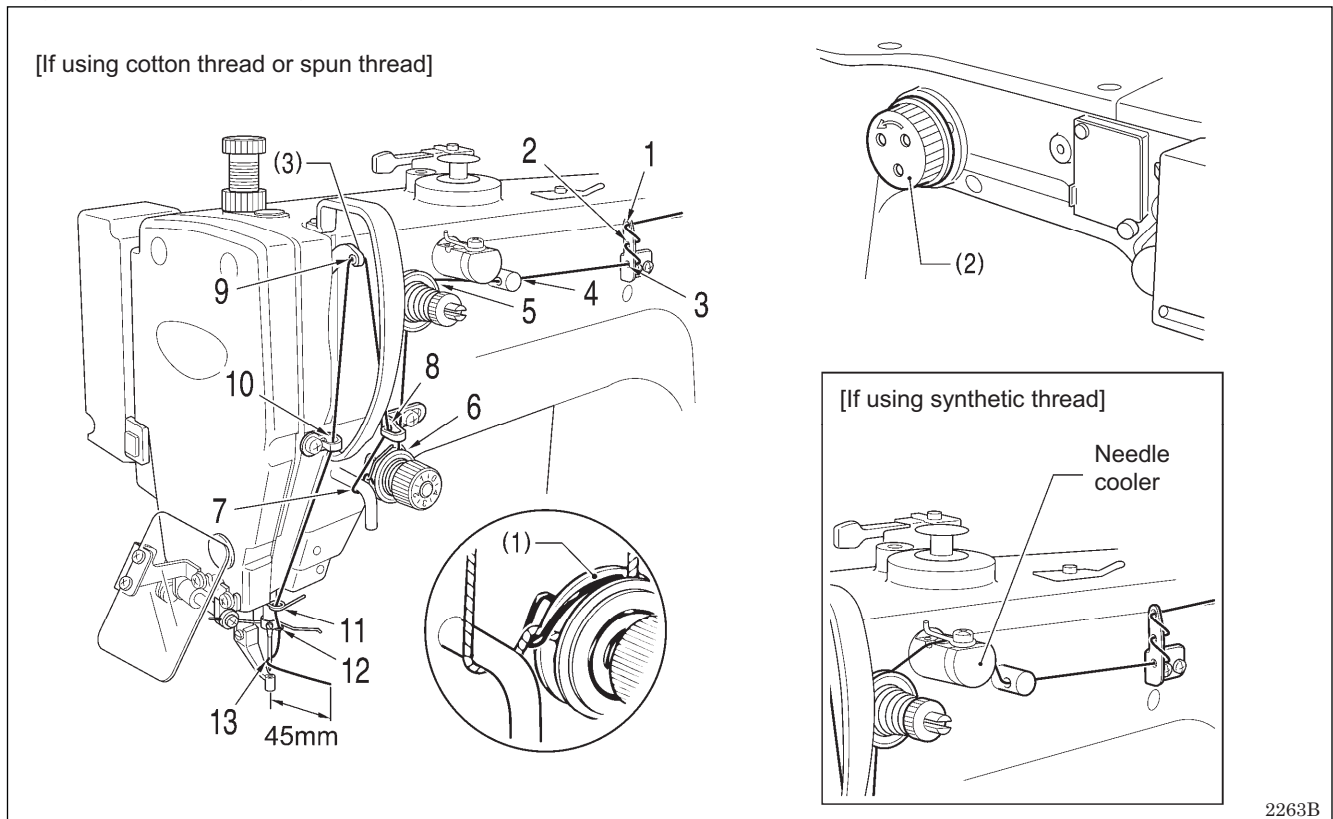

* When using threading mode for threading, the tension discs (1) will open so that the thread can be threaded more easily. (Refer to following page.)



- Turn the machine pulley (2) and raise the thread take-up (3) to its highest position before threading the upper thread. (This will make threading easier and it will prevent the thread from coming out at the sewing start.)
- When threading the thread through the needle, allow a distance of approximately 45 mm between the needle hole and the end of the thread. If the trailing length of the thread is too long, it may cause the thread to become tangled.

<Threading mode>

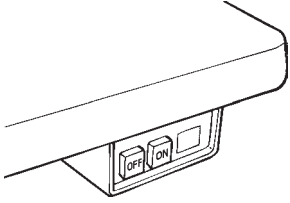
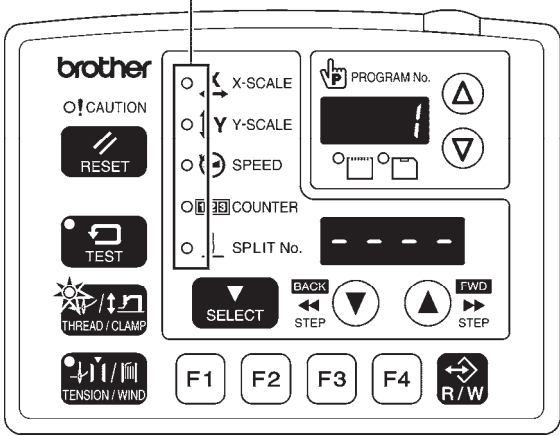
Threading mode is safe because the sewing machine will not start even when the foot switch is depressed.

<p>1</p>		<p>Turn on the power switch.</p> <p style="text-align: right;">4421Q</p>
<p>2</p>	<p>All indicators switch off</p>  <p>THREAD/CLAMP indicator illuminates MENU indicator switches off</p> <p style="text-align: right;">4427Q</p>	<p>Press the THREAD/CLAMP key.</p>  <ul style="list-style-type: none"> • The intermittent presser foot and the work clamp will drop. • The tension discs will open.
<p>3</p>	<p>Threading the thread.</p> <ul style="list-style-type: none"> • When 5 minutes have passed, the buzzer will sound and the tension discs will close. 	
<p>4</p>	<p>Ending threading mode</p>  <p>THREAD/CLAMP indicator switches off</p>	<p>Press the THREAD/CLAMP key.</p> <ul style="list-style-type: none"> • The intermittent presser foot and the work clamp will return to where they were before threading mode began.

4-3. Foot switch operating method

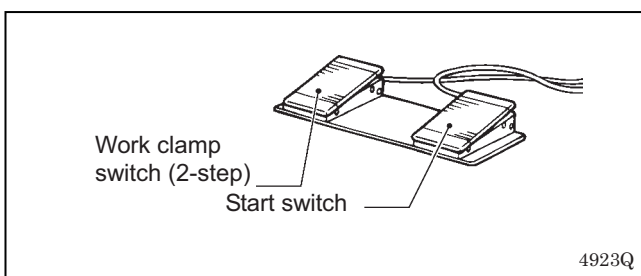

When the work clamp switch (left side) is depressed, the work clamp will be lowered, and when the start switch (right side) is depressed, the sewing machine will start.

* The work clamp lowering method can be changed using memory switch No. 002. (Refer to "6-3. List of memory switch settings.")

4-4. Winding the lower thread

! CAUTION



Do not touch any of the moving parts or press any objects against the machine while winding the lower thread. Injury or damage to the sewing machine may result.

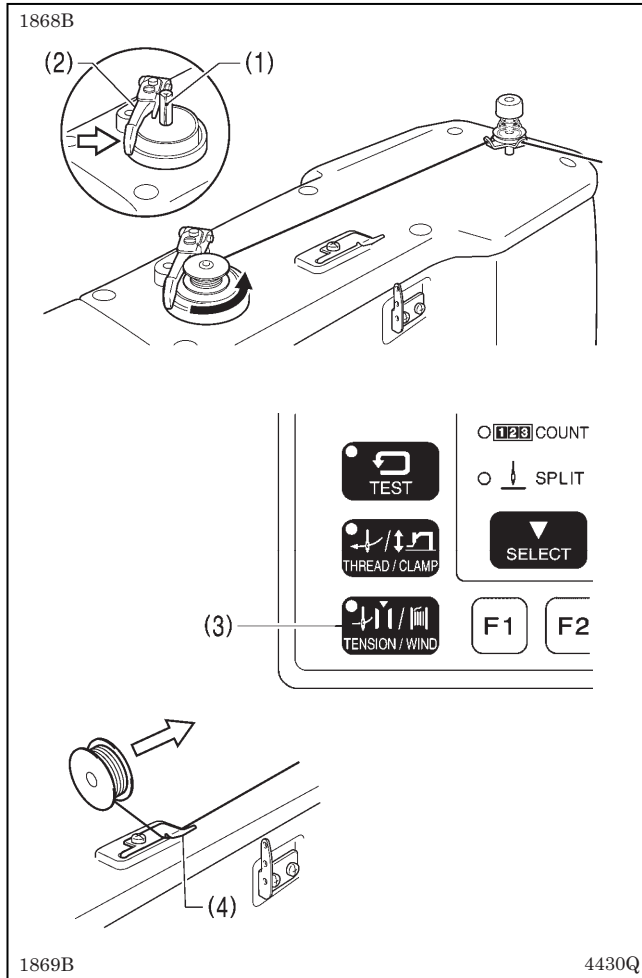

1. Place the bobbin onto the bobbin winder shaft (1).
2. Thread the thread as shown in the illustration, wind the thread around the bobbin several times, and then press the bobbin presser arm (2).
3. Turn on the power switch.
4. Depress the work clamp switch as far as it will go and then release it.
(The work clamp will drop.)
5. Depress the start switch as far as it will go and then release it.
(Home position detection will be carried out.)
6. Check that the needle does not touch the work clamp, and then depress the work clamp switch as far as it will go and then release it.
(The work clamp will drop.)
7. While pressing the TENSION/WIND key (3), depress the start switch.
8. Release the TENSION WIND key (3) after the machine starts operating, and keep depressing the foot switch until the lower thread stops being wound onto the bobbin.
(If you release the foot switch before winding is complete, and then depress it again while pressing the TENSION/ WIND key (3), winding will start again.)
9. Once winding of the set amount of lower thread (80 - 90% of the bobbin capacity) is completed, the bobbin presser arm (2) will return automatically.
10. Remove the bobbin, hook the thread onto the knife (4), and then pull the bobbin in the direction of the arrow to cut the thread.

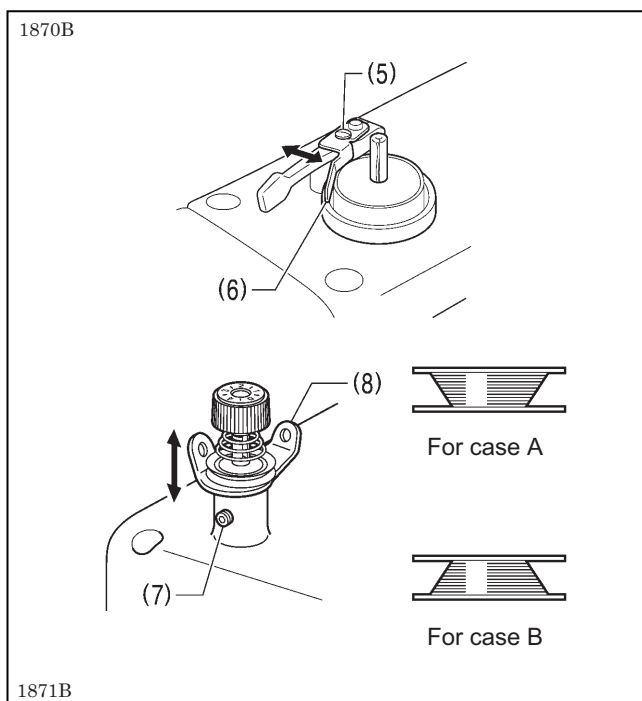

Adjusting the bobbin winding amount

Loosen the screw (5) and move the bobbin presser (6) to adjust.

If the thread winds onto the bobbin unevenly

Loosen the set screw (7) and move the bobbin winder tension assembly (8) up and down to adjust.

* For case A, move the bobbin winder tension assembly (8) down, and for case B, move it upward.

4-5. Installing the bobbin case

! CAUTION

Turn off the power switch before installing the bobbin case.

If the foot switch is depressed by mistake, the sewing machine might start operating and injury could result.

1872B

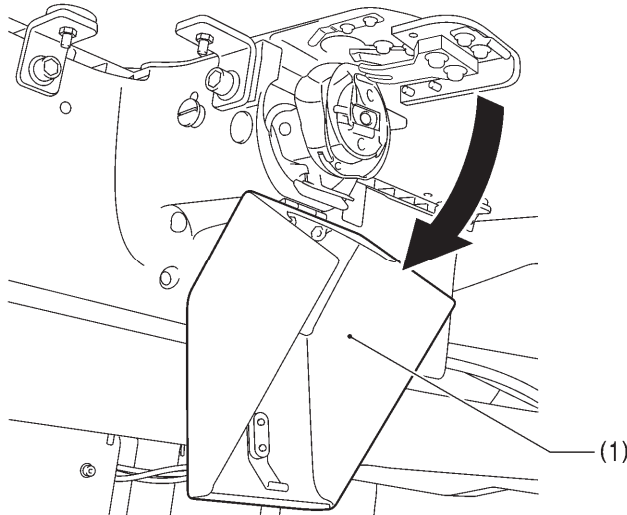

1897B

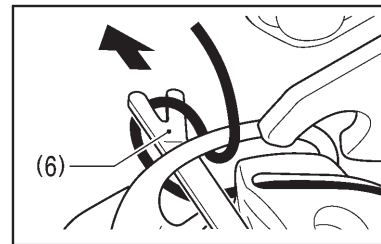
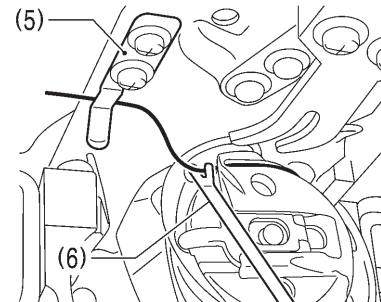

1873B

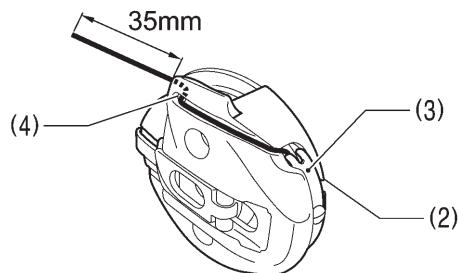
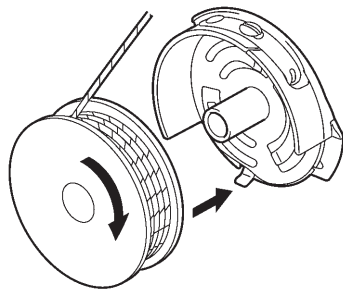

1874B

1. Pull the hook cover (1) downward to open it.
2. While holding the bobbin so that the thread winds to the right, insert the bobbin into the bobbin case.
3. Pass the thread through the thread slot (2), pass it underneath the spring (3), and then pass it through the thread guide (4), leaving a trailing-out length of about 35 mm.
4. Hold the latch on the bobbin case and insert the bobbin case into the rotary hook.
5. Clamp the lower thread in the thread hold spring (5).
6. Use the threading bar (6) to pass the thread through the window of the inner rotary hook. (The thread will be released from the thread hold spring (5).)

4-6. Thread tension

[Thread tension reference]

Upper thread	#20 or similar
Lower thread	#20 or similar
Upper thread tension (N)	1.0 – 1.6
Lower thread tension (N)	0.4 – 0.6
Pre-tension (N)	0.3 – 0.6
Needle	DP x 17 #19
Normal sewing speed	2,000 sti/min

4-6-1. Lower thread tension

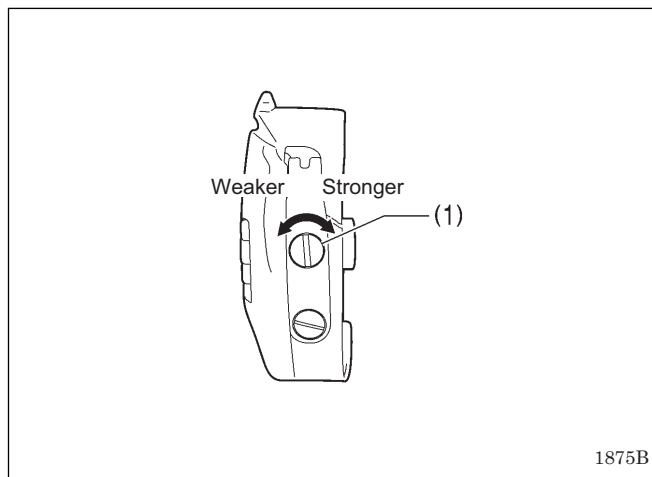

Adjust the lower thread tension by turning the adjusting screw (1).

4-6-2. Upper thread tension

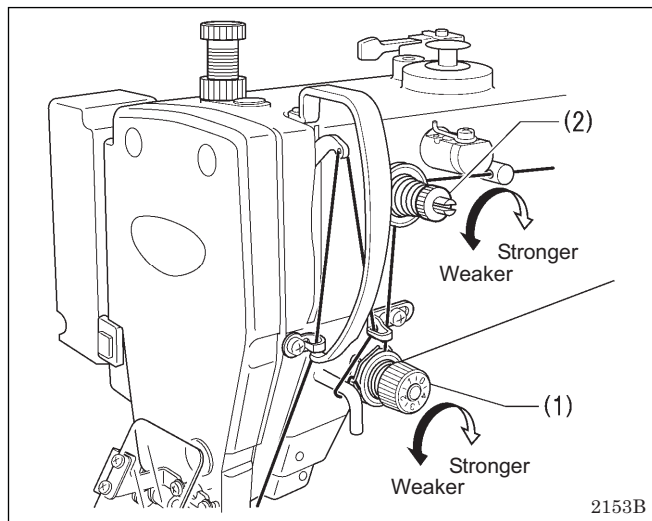

1. Turn the tension nut (1) (main tension) to adjust the tension as appropriate for the material being sewn.
2. Use the tension nut (2) (sub tension) to adjust the upper thread trailing length to about 45 mm.

4-7. Home position detection

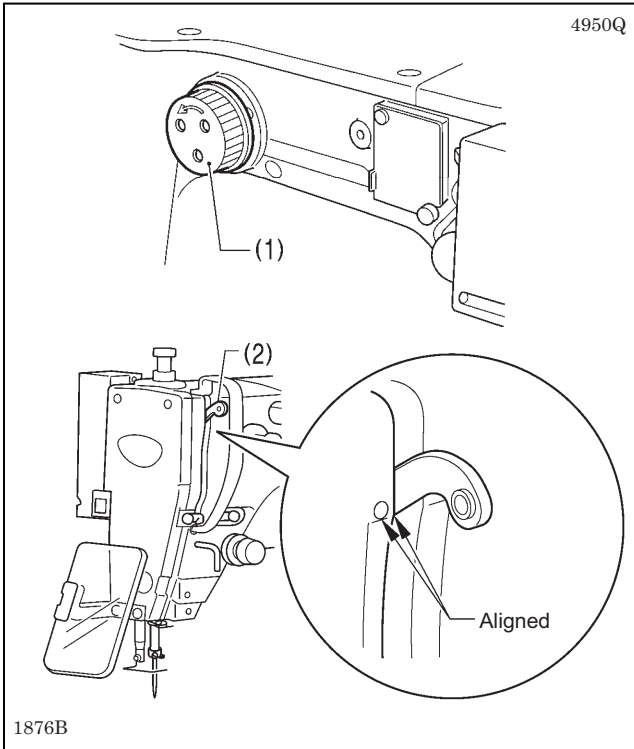

Before starting home position detection, check that the needle bar is at its highest position.

Turn the pulley (1) until the ridge at the bottom of the thread take-up (2) is aligned with the O mark on the arm.

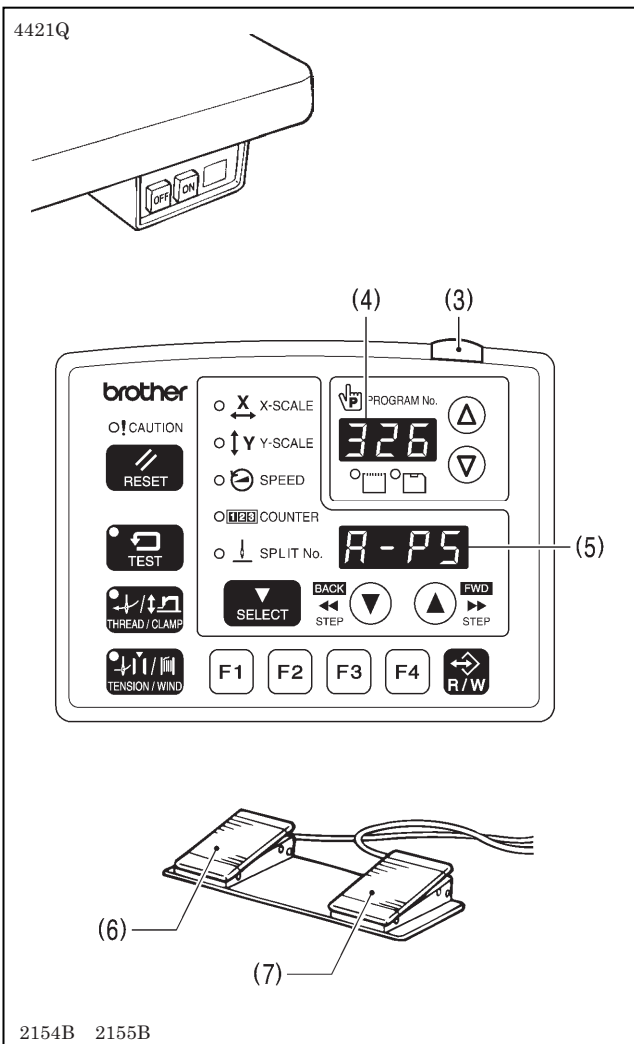

1. Turn on the power switch.
The power indicator (3) will illuminate, and the model name [326] will appear in the PROGRAM No. display (4) and [A-PS] will appear in the menu display (5).

After this, the program number will flash in the PROGRAM No. display (4).

2. Depress the work clamp switch (6) to lower the work clamp, and then depress the start switch (7). (After home position detection is carried out, the work clamp will move to the sewing start position and then it will rise.)

* For programs with a large number of stitches, the buzzer will sound after the home position is detected, and then the work clamp will move to the sewing start position.

NOTE:

If error "E110" is displayed when the start switch (7) is depressed, turn the pulley (1) in the direction of operation to clear the error display.

5. USING THE OPERATION PANEL (BASIC OPERATIONS)

5-1. Name and function of each operation panel item

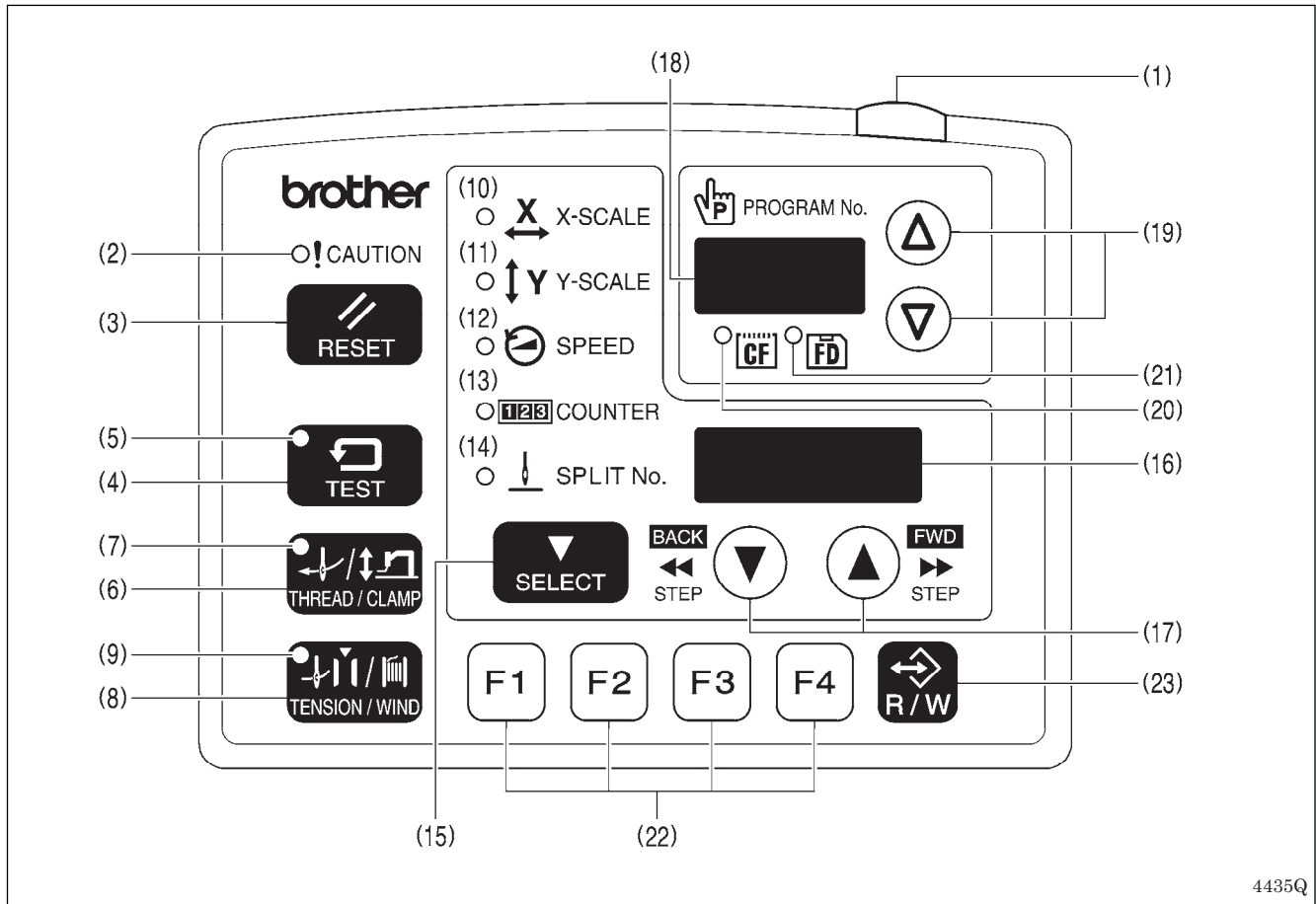



- (1) Power indicator
Illuminates when the power is turned on.
- (2) CAUTION indicator
Illuminates when an error occurs.
- (3) RESET key
Used to reset errors.
- (4) TEST key
Used to start test mode.
- (5) TEST indicator
Illuminates when the TEST key (4) has been pressed.
- (6) THREAD/CLAMP key
Used to start threading mode or work clamp height setting mode.
- (7) THREAD/CLAMP indicator
Illuminates when the THREAD/CLAMP key (6) has been pressed.
- (8) TENSION/WIND key
Used to wind the lower thread.
- (9) TENSION/WIND indicator
Spare

- (10) X-SCALE indicator
Illuminates when the SELECT key (15) is pressed to shown the X-scale setting.
- (11) Y-SCALE indicator
Illuminates when the SELECT key (15) is pressed to shown the Y-scale setting.
- (12) SPEED indicator
Illuminates when the SELECT key (15) is pressed to shown the sewing speed setting.
- (13) COUNTER indicator
Illuminates when the SELECT key (15) is pressed to shown the lower thread or production counter setting.
- (14) SPLIT No. indicator
Illuminates when the SELECT key (15) is pressed to show the split setting when split data (for specifying a pause while the program is running) exists.
- (15) SELECT key
Used to select a menu (X-scale, Y-scale, sewing speed and counter).
- (16) Menu display
Displays information such as menu setting values, memory switch settings and error codes.
- (17) Setting keys ▼ ▲
Used to change the value which is displayed in the menu display (16).
In addition, it is used to move the needle position forward and back when sewing has been paused.
- (18) PROGRAM No. display
Displays information such as program numbers.
- (19) Setting keys ▽ ▲
Used to change the value which is displayed in the PROGRAM No. display (18).
- (20) CF media indicator
Illuminates when a CF card (external media) is inserted while the power is turned on.
- (21) FD media indicator
Illuminates when a floppy disk (external media) is inserted while the power is turned on. [Option compatibility]
- (22) Function keys [F1, F2, F3, F4]
Used to select user programs and to set and select cycle programs.
- (23) R/W key
Used to read data from and write data to external media.

CF™ is a trademark of SanDisk Corporation.

5-2. Loading sewing data

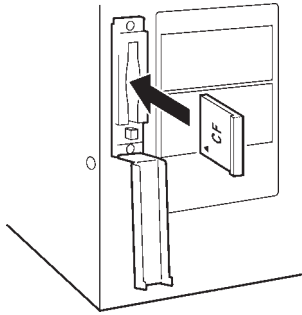
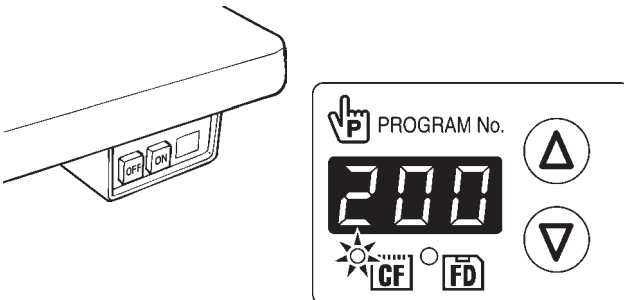
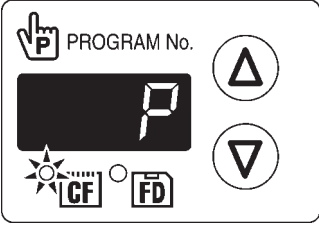
Refer to "7-1. Notes on handling CF cards (sold separately)" for details on using CF cards.

<p>1</p>		<p>With the power turned off, insert the CF card into the CF slot.</p> <p>NOTE:</p> <ul style="list-style-type: none"> • Make sure the CF card is facing the correct way when inserting it. • Always be sure to keep the cover closed except when inserting and removing the CF card. If this is not done, dust may get inside and cause problems with operation.
<p>2</p>	 <p>CF media indicator illuminates</p>	<p>Turn on the power switch. Press the Δ or ∇ key to select the program number (100 – 999). * The "----" display is used to check the feed home position.</p>
<p>3</p>	 <p>Loading</p>	<p>Press the R/W key.</p>  <ul style="list-style-type: none"> • The buzzer will sound and the selected sewing data will be loaded from the CF card and copied into the sewing machine's internal memory.
<p>4</p>	<p>Loading complete The PROGRAM No. display will change from " P" to the selected program number. Turn off the power switch, remove the CF card, and then close the cover of the CF slot.</p>	

5-3. Setting the program number

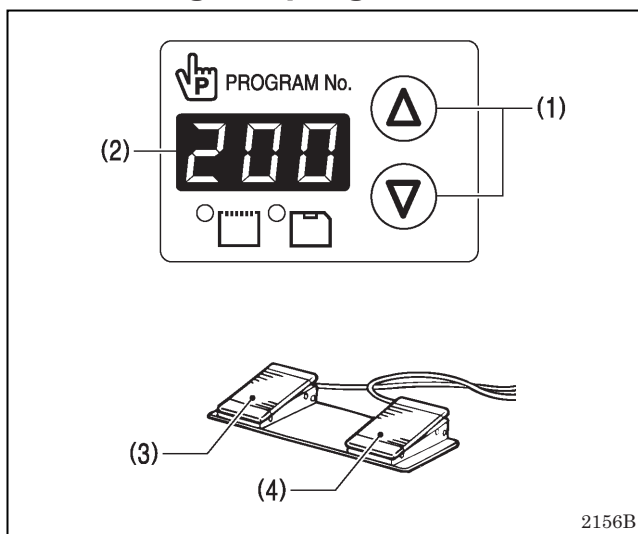

1. Press the Δ or ∇ key (1) to select the program number that is loaded into the internal memory.
 - The program number will flash in the PROGRAM No. display (2).
 - "----" will appear at the time of shipment from the factory. (For checking feed home position)
2. Depress the work clamp switch (3) to lower the work clamp, and then depress the start switch (4).
 - The work clamp will move to the sewing start position, and then the program number will be applied.
 - The program number will stop flashing and illuminate steadily.

NOTE:

After completing the setting, be sure to refer to "5-6. Checking the sewing pattern" to check that the needle drop position is correct.

5-4. Setting the X-scale and Y-scale

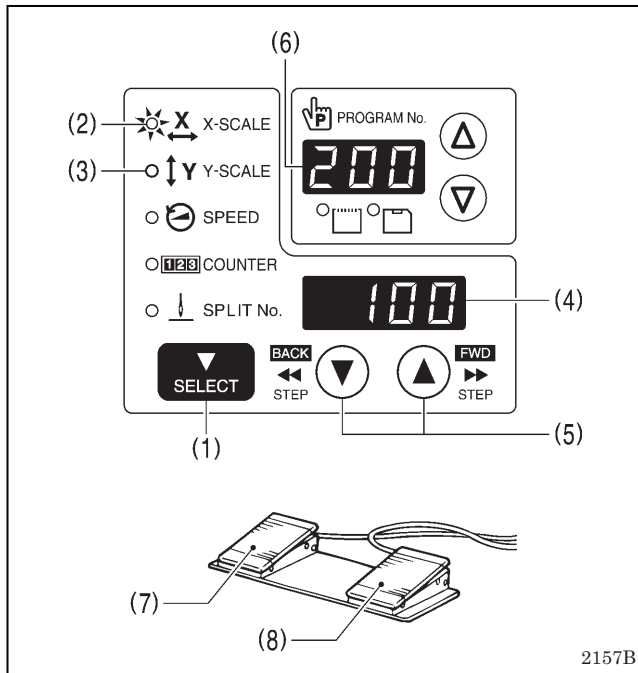

The scales are set to 100 (%) at the time of shipment from the factory.

- Press the SELECT key (1) so that the X-SCALE indicator (2) (for X-scale setting) or the Y-SCALE indicator (3) (for Y-scale setting) is illuminated.
 - The setting value (%) will appear in the menu display (4).
 - When memory switch no. 402 is set to "ON", the settings will be displayed in units of mm.
- Press the ▲ or ▼ key (5) to set the scale (0 – 400).
 - The program number will flash in the PROGRAM No. display (6).
- Depress the work clamp switch (7) to lower the work clamp, and then depress the start switch (8).
 - The work clamp will move to the sewing start position, and then the scales will be applied.
 - The program number will stop flashing and illuminate steadily.

NOTE:

After completing the setting, be sure to refer to "5-6. Checking the sewing pattern" to check that the needle drop position is correct.

5-5. Setting the sewing speed

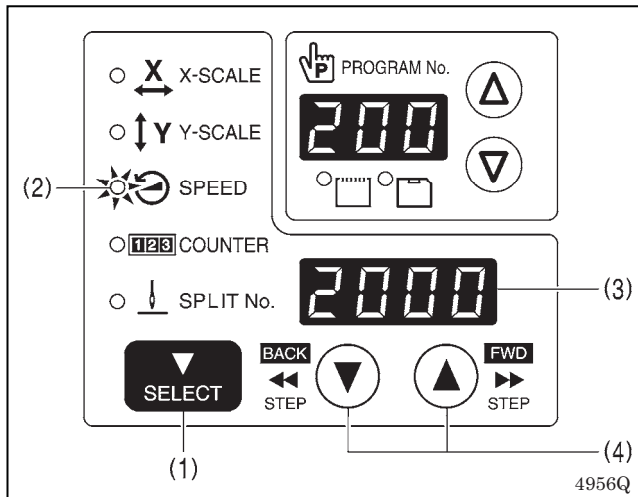





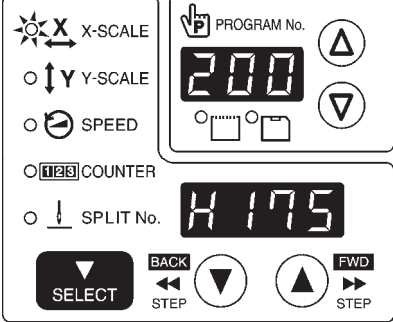
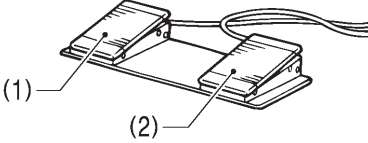
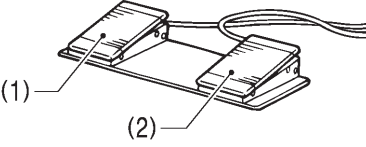

The sewing speed is set to 2000 (sti/min) at the time of shipment from the factory.

- Press the SELECT key (1) until the SPEED indicator (2) illuminates.
 - The setting value (sti/min) will appear in the menu display (3).
- Press the ▲ or ▼ key (4) to set the sewing speed. (Sewing speed setting: 400 – 2700)

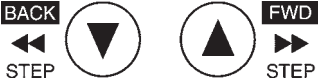

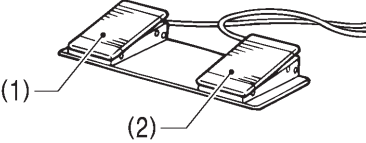
5-6. Checking the sewing pattern

Use test feed mode to check the needle movement with only the feed mechanism operating.
Check that the needle hole does not come out from the frame of the work clamp.

<p>1</p>	 <p>TEST indicator illuminates</p> <p>Press the TEST key.</p>
<p>2</p>	 <p>COUNTER indicator illuminates</p> <p>Select the program number to be checked, and then set the X-scale and the Y-scale.</p> <ul style="list-style-type: none"> The program number will flash. <p>Depress the work clamp switch (1) to lower the work clamp, and then depress the start switch (2).</p> <ul style="list-style-type: none"> The work clamp will move to the sewing start position, and then the program number will stop flashing and illuminate steadily. The number of stitches will appear in the menu display.  <p style="text-align: right;">4957Q 4014M</p>
<p>3</p>	<p>Starting continuous test feed mode</p> <p>Depress the work clamp switch (1) to lower the work clamp, and then depress and release the start switch (2).</p> <ul style="list-style-type: none"> The work clamp will start moving continuously one stitch at a time.  <p>[Fast-forward test mode] If the work clamp switch (1) is depressed while the work clamp is moving, the feeding speed can be increased while the work clamp switch (1) is depressed.</p> <p style="text-align: right;">4014M</p> <div style="border: 1px solid black; padding: 5px; margin-top: 10px;">  <p>TEST indicator illuminates</p>  <p>If you press the ▲ key, the feed mechanism will move forward one stitch at a time, and if you press the ▼ key, the feed mechanism will move backward one stitch at a time. (The feed will move quicker if you keep the key pressed down.)</p>  <p>TEST indicator switches off</p>  <p>If you would like sewing to start while test feeding is in progress, press the TEST key to switch off the TEST indicator. When the start switch (2) is depressed, sewing will start.</p> <p style="text-align: right;">4443Q 4014M</p> </div>
<p>4</p>	<p>If test feeding continues to the final stitch, it will then stop.</p> <p>Press the TEST key.</p>  <p>TEST indicator switches off</p>

5-7. Setting the height of the intermittent presser foot

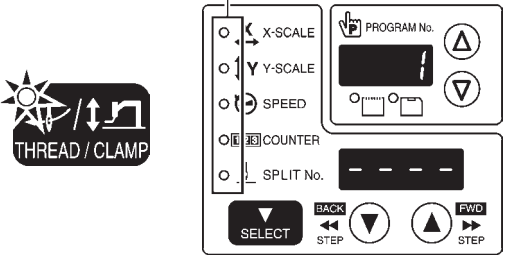
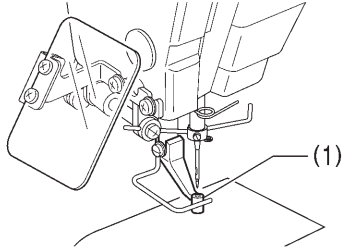
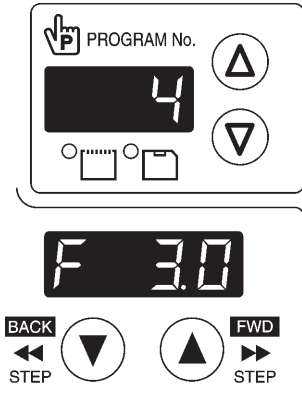
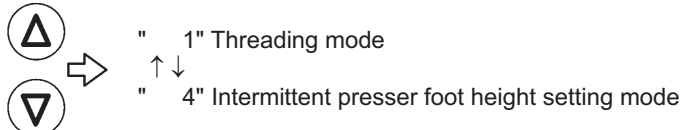
You can use the operation panel to change the setting value for the intermittent presser foot height.

<p>1</p>	<p>All indicators switch off</p>  <p>THREAD/CLAMP indicator illuminates MENU indicator switches off</p>	<p>Press the THREAD/CLAMP key. The sewing machine will switch to threading mode.</p> <ul style="list-style-type: none"> " 1" will appear in the PROGRAM No. display and the intermittent presser foot (1) will drop.  <p style="text-align: right;">4445Q 2158B</p>
<p>2</p>		<p>Press the Δ key. The sewing machine will switch to intermittent presser foot height setting mode.</p> <ul style="list-style-type: none"> " 4" will appear in the PROGRAM No. display and the intermittent presser foot (1) will rise to the setting value that appears in the menu display. (Intermittent presser foot height setting: 0.0 – 10.0) <p>Press the \blacktriangle or \blacktriangledown key to set the intermittent presser foot height.</p> <ul style="list-style-type: none"> The intermittent presser foot (1) will be raised or lowered to the height of the new value that has been set. <p>NOTE: After making the setting, be sure to turn the pulley once by hand and check that the intermittent presser foot (1) does not touch the needle bar.</p> <p style="text-align: right;">5225Q</p>
<p><Changing modes></p>  <p style="text-align: right;">4016M</p>		
<p>3</p>	<p>Ending setting mode</p>  <p>THREAD/CLAMP indicator switches off</p>	<p>Press the THREAD/CLAMP key.</p> <ul style="list-style-type: none"> The setting values will be memorized. The intermittent presser foot (1) will return to the status that it was at before the sewing machine was switched to setting mode.

Intermittent presser foot operation

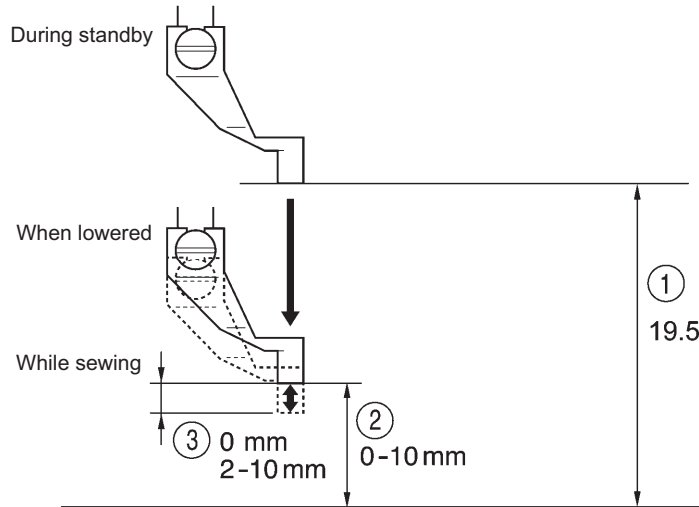

① **Intermittent presser foot lift amount**
19.5mm

② **Intermittent presser foot height**
The settings can be made by the above operations.
However, if the intermittent presser foot height is set to a smaller setting than the intermittent presser foot stroke, the intermittent presser foot will not drop in order to prevent it from coming into contact with the needle plate. (Refer to page 63.)

③ **Intermittent stroke**
Refer to "10-14. Changing the intermittent stroke" when making the adjustment.

1899B







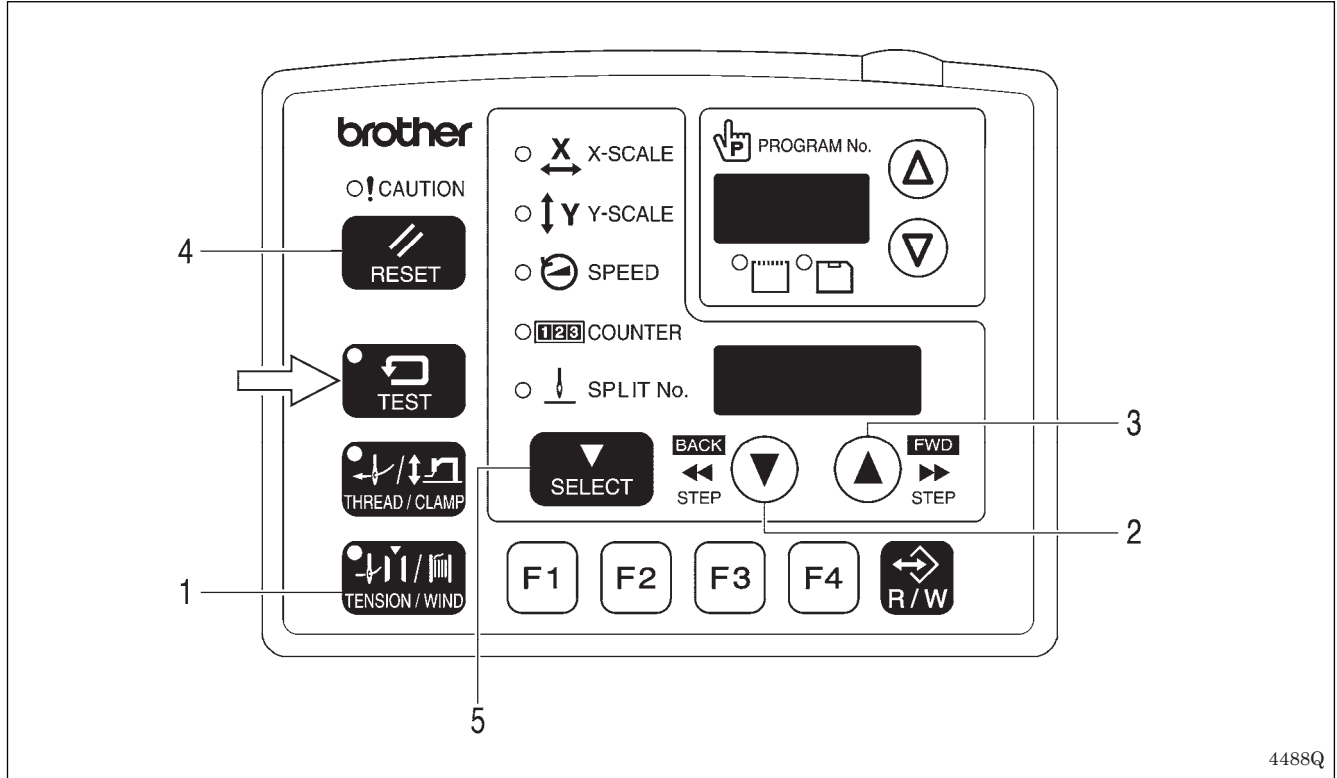



6. USING THE OPERATION PANEL (ADVANCED OPERATIONS)

6-1. List of advanced functions









While holding down the TEST key, press the corresponding combination key.

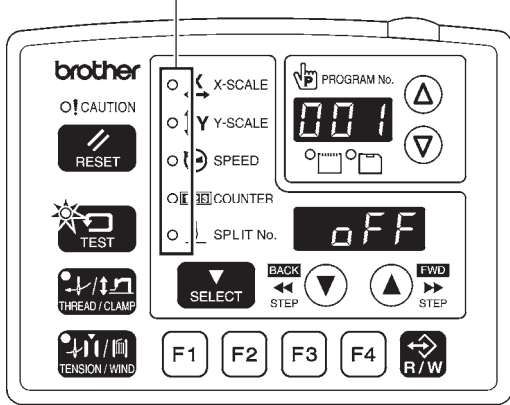

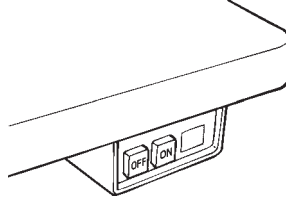
4488Q

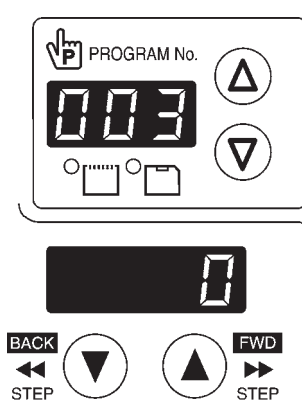
1	 + 	Memory switch setting mode Refer to "6-2. Setting memory switches".	4489Q
2	 + 	Lower thread counter setting mode Refer to "6-4. Using the lower thread counter".	4490Q
3	 + 	Production counter setting mode Refer to "6-5. Using the production counter".	4491Q
4	When SPEED indicator is illuminated  + 	Production counter temporary display function Refer to "6-5. Using the production counter".	4492Q
5	 + 	User program setting mode Refer to "6-7. Using user programs".	4493Q

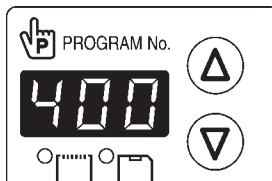
6-2. Setting memory switches

<p>1</p>	<p>All indicators switch off</p>  <p>Menu indicator switches off TEST indicator illuminates</p>	<p>While pressing the SELECT key, turn on the power switch. * Keep pressing the SELECT key until the model name is displayed and the buzzer beeps once.</p>   <p>or</p> <p>With the power turned on, press the TEST key and the TENSION/WIND key simultaneously.</p>   <ul style="list-style-type: none"> The memory switch number will appear in the PROGRAM No. display, and its setting value will appear in the menu display. <p>4449Q 4421Q</p>
<p>2</p>	 <p>If you would like to display only the numbers of memory switches that have been changed from default settings</p>  	<p>Press the Δ or ∇ key to select the memory switch number.</p> <p>Press the \blacktriangle or \blacktriangledown key to change the setting.</p> <p>4961Q</p> <p>While pressing the SELECT key, press the Δ or ∇ key.</p> <ul style="list-style-type: none"> The numbers of memory switches that have been changed from default settings will appear in order. If no memory switches have been changed from their default settings, the display will not change and the buzzer will beep twice. <p>4452Q</p>
<p>3</p>	<p>Ending setting mode</p>  <p>TEST indicator switches off</p>	<p>Press the TEST key.</p> <ul style="list-style-type: none"> The changes will be memorized and the sewing machine will switch to home position detection standby.



- If you would like to return the setting for a single memory switch to the default setting, press the RESET key while the number for that memory switch is displayed.
- To return the settings for all memory switches to the default settings, keep pressing the RESET key for **two or more seconds** until the buzzer makes a long beep.

6-3. List of memory switch settings





No.	Setting range	Setting items	Initial value
001		Work clamp lift timing after sewing is completed	ON
	OFF	Lifts at the final stitch position.	
	ON	Lifts after moving to the sewing start position.	
002		Separate-type work clamp drop operation (pneumatic work clamp specifications)	0
	0	Left and right work clamp drop at the same time.	
	1	Work clamp drops in the order left → right.	
	2	Work clamp drops in the order right → left.	
100		Sewing start speed	OFF
	OFF	The sewing speed for the first 1 – 5 stitches is set by memory switch numbers 151 – 155. (Refer to the service manual for details of memory switch Nos. 151 – 155.)	
	ON	1st stitch at 400 sti/min, 2nd stitch at 400 sti/min, 3rd stitch at 600 sti/min, 4th stitch at 900 sti/min, 5th stitch at 2,000 sti/min	
200		Single-stitch test feed	OFF
	OFF	Test feed starts when the foot switch (start switch) is depressed, and it continues automatically until the final stitch.	
	ON	Test feed is carried out one stitch at a time when the foot switch (start switch) is depressed (feed becomes continuous if the foot switch [start switch] is continuously depressed). In addition, when the TEST indicator is illuminated, test feeding will move forward one stitch at a time when the machine pulley is turned by hand.	
300		Production counter display	OFF
	OFF	Lower thread counter display	
	ON	Production counter display	
400		User programs	OFF
	OFF	Disabled	
	ON	User program mode is enabled.	
401		Cycle programs	OFF
	OFF	Disabled	
	ON	When sewing user programs, the set programs are sewn in numeric order.	
402		Maximum reduction ratio (mm display) (*)	OFF
	OFF	Displayed as %.	
	ON	Displayed as mm.	
403		Split mode selection	0
	0	Continuous split (split menu is disabled before split detection)	
	1	Continuous split (split menu is always enabled)	
	2	Independent split	

* The mm display may differ slightly from the actual sewing size.

6-4. Using the lower thread counter

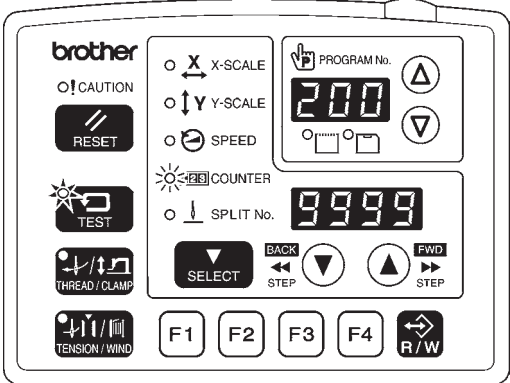
If you use the lower thread counter to set the number of articles which can be sewn with the amount of lower thread available, you can stop the lower thread running out in the middle of sewing a pattern.

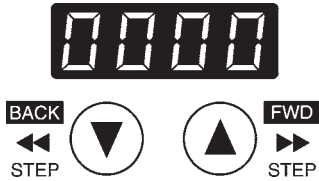
<Setting defaults>

<p>1</p>		<p>While pressing the TEST key, press the ▼ key.</p>   <ul style="list-style-type: none"> The initial value which was set previously will appear in the menu display.
<p>TEST indicator illuminates, COUNTER indicator flashes 4962Q 4455Q</p>		
<p>2</p>		<p>Press the ▲ or ▼ key to set the initial value.</p> <ul style="list-style-type: none"> The initial value can be set from 1 ("0001") to 9999 ("9999"). If the initial value is set to "0000", the lower thread counter will not operate. If you press the RESET key during setting mode, the value will become "0000". <div style="border: 1px dashed black; padding: 5px;">  <p>If you press the R/W key during setting mode, the initial value for the program number being displayed will be stored, and you can set the lower thread counter separately for each item of sewing data.</p> </div> <p>4456Q</p>
<p>3</p>	<p>Ending setting mode</p>  <p>TEST indicator switches off</p>	<p>Press the TEST key.</p> <ul style="list-style-type: none"> The initial value will be memorized.

<Lower thread counter operation>



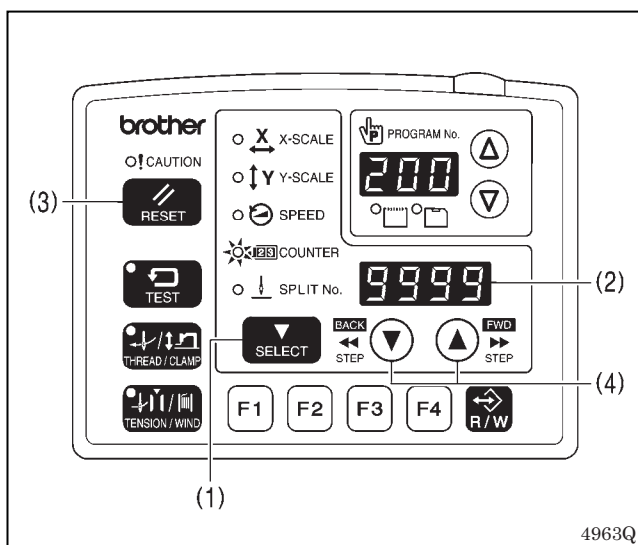

If you press the SELECT key (1) to select the counter display menu when memory switch no. 300 is set to "OFF", the COUNTER indicator will illuminate and the lower thread counter will appear in the menu display (2).

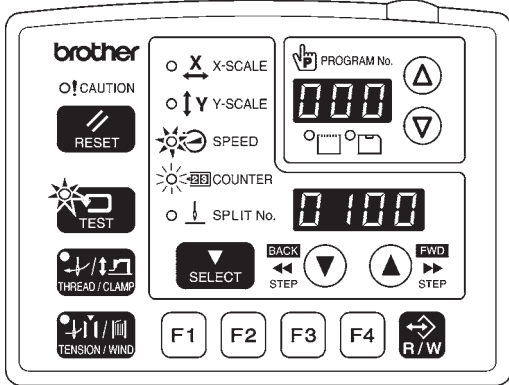

- Each time the sewing of a single article is completed, the value shown in the menu display (2) is reduced by 1.
- When the lower thread counter reaches "0000", the buzzer will sound continuously. The sewing machine will not operate during this time, even if the foot switch is depressed.
- When you press the RESET key (3), the buzzer will stop, the initial value will appear in the menu display (2) and sewing will be possible.
 - If no initial value has been set, the display will be "0000".
- You can press the ▲ or ▼ key (4) to set the lower thread counter to a desired value. However, this value will not be stored as the initial value.
- If a lower thread counter value is set, the lower thread counter will operate even if the lower thread counter is not being displayed.

6-5. Using the production counter

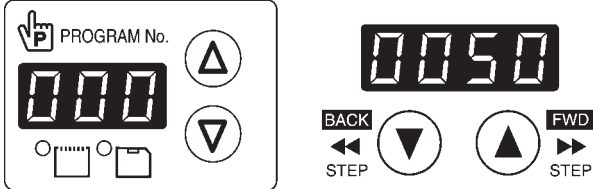
<Setting the counter value>

1	 <p style="text-align: center;">TEST indicator and SPEED indicator illuminate COUNTER indicator flashes</p>	<p>While pressing the TEST key, press the ▲ key.</p> <div style="display: flex; justify-content: space-around; align-items: center;"> <div style="border: 1px solid black; padding: 5px; text-align: center;">  TEST </div> <div style="border: 1px solid black; padding: 5px; text-align: center;">  FWD STEP </div> </div> <ul style="list-style-type: none"> The counter value that was previously set will appear as a 7-digit number in the PROGRAM No. display and the menu display.
2		<p>Press the ▲ or ▼ key to set the counter value.</p> <ul style="list-style-type: none"> The counter value can be set to between "000" "0000" and "999" "9999". If you press the RESET key during setting mode, the value will become "000" "0000".
3	<p>Ending setting mode</p>  <p style="text-align: center;">TEST indicator switches off</p>	<p>Press the TEST key.</p> <ul style="list-style-type: none"> The counter value will be memorized.

<Production counter operation>

If you press the SELECT key (1) to select the counter display menu when memory switch no. 300 is set to "ON", the SPEED and COUNTER indicators will illuminate and the production counter will appear in the menu display (2).

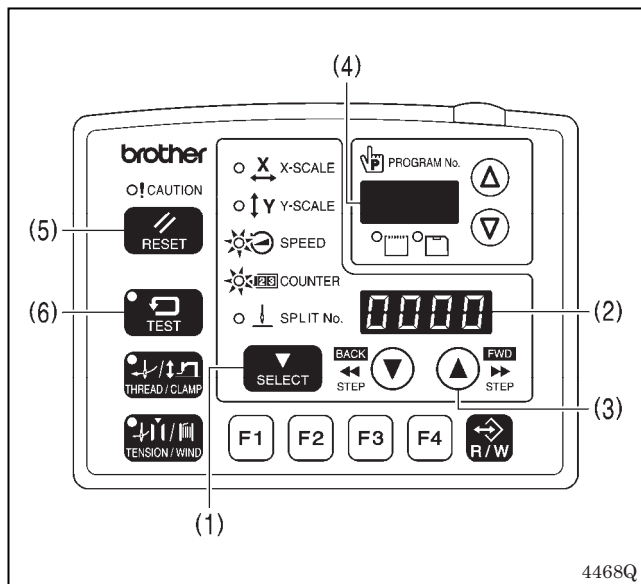

- Each time the sewing of a single article is completed, the value shown in the menu display (2) is increased by 1.
- While the ▲ key (3) is being pressed, the first three digits will appear in the PROGRAM No. display (4) so that the total number of digits displayed will be seven.
- If you press the RESET key (5) for 2 seconds or more, the counter value will be reset to [0000].

Temporary display function

You can display the production counter temporarily while the lower thread counter is being displayed.

When the SPEED indicator is illuminated, hold down the TEST key (6) and then press the RESET key (5) to display the production counter in the menu display (2).

Press the TEST key (6) or the SELECT key (1) to switch the menu back to the normal menu display.

* You can start sewing while the temporary display still appears.

6-6. Setting the split number



4964Q

If split data (data that causes sewing to pause) exists within a single program, the numbers that are used to specify the patterns that are separated by split data are called split numbers.

Pattern 1: Split No. 1
 Pattern 2: Split No. 2
 Pattern 3: Split No. 3

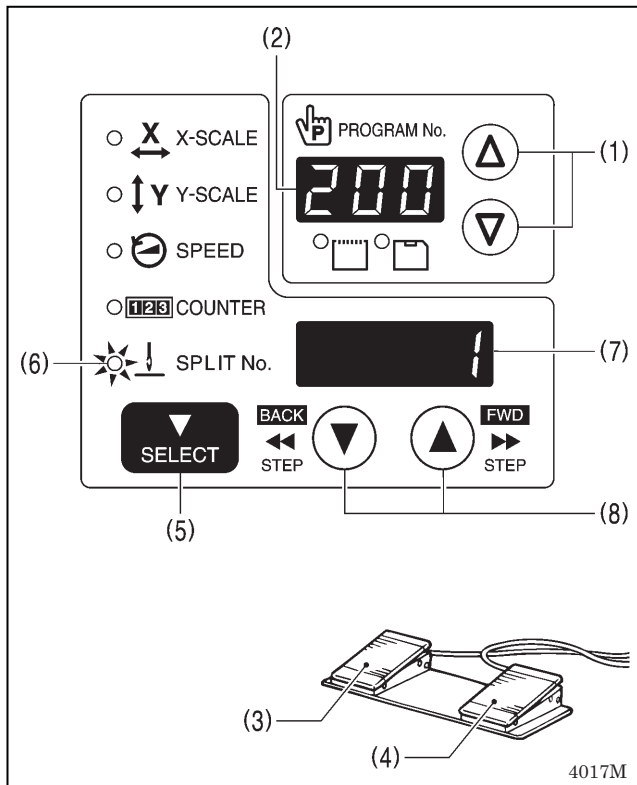

- Press the Δ or ∇ key (1) to select a program number for a program that contains split data.
 - The program number will flash in the PROGRAM No. display (2).
- Depress the work clamp switch (3) to lower the work clamp, and then depress the start switch (4).
 - The work clamp will move to the sewing start position, and then the program number will be applied.
 - The program number will stop flashing and illuminate steadily.
- Press the SELECT key (5) so that the SPLIT No. indicator (6) illuminates.
 - The split number will appear in the menu display (7).
- Press the \blacktriangle or \blacktriangledown key (8) to set the split number.

The setting for memory switch No. 403 lets you select the split mode.

[Continuous split]

Memory switch No. 403 = 0 (Split mode is enabled after split data is detected)

Memory switch No. 403 = 1 (Split mode is always enabled)

- Sewing is carried out each time in the order of steps 1 \rightarrow 2 \rightarrow 3 \rightarrow 1 (for example, if there are two sections of split data).

[Independent split]

Memory switch No. 403 = 2

- The pattern for the displayed split number is sewn independently.









6-7. Using user programs

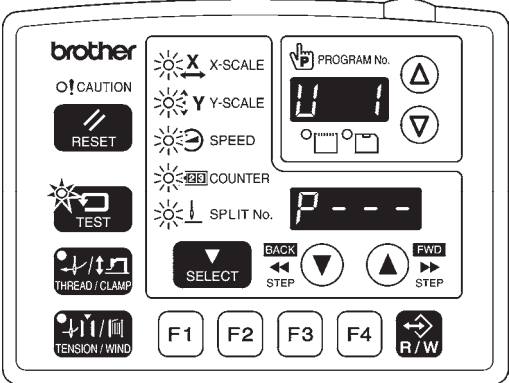

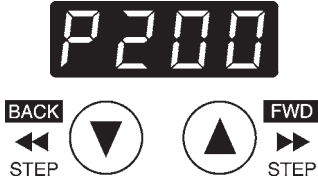
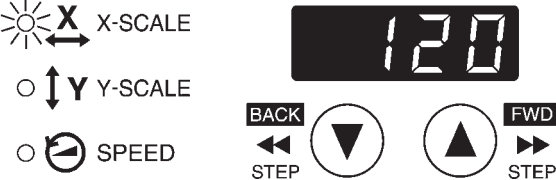

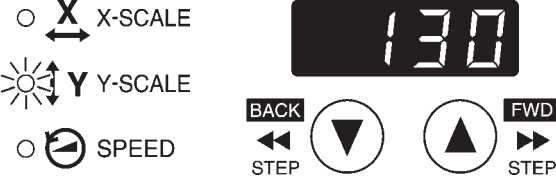

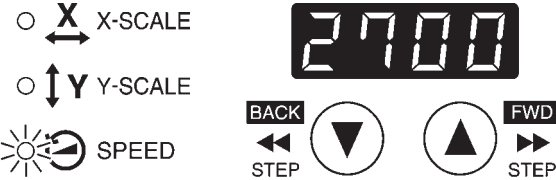
Up to 50 different combinations of settings including program no., X-scale, Y-scale, sewing speed, work clamp height and intermittent presser foot height can be memorized as user programs (U1 to U50).

If you are sewing certain patterns over and over again, it is useful to record the settings for these patterns into a user program.

User programs are enabled when memory switch no. 400 is set to "ON".

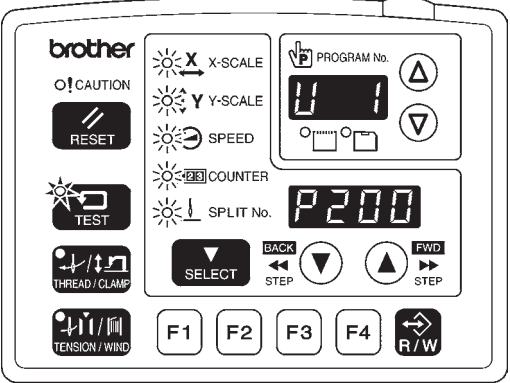
<Recording user programs>

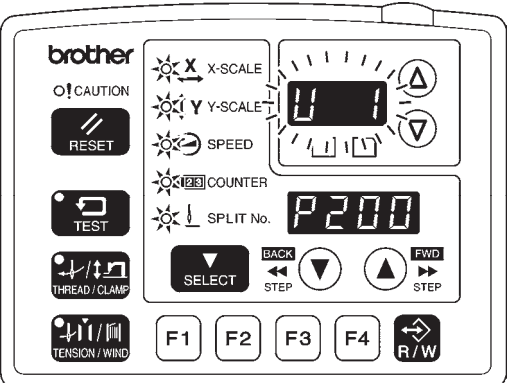
<p>1</p>	<p>Select a user program number.</p>  <p>TEST indicator illuminates, MENU indicator flashes</p>	<p>While pressing the TEST key, press the SELECT key.</p>   <ul style="list-style-type: none"> Switch to user program recording mode. Check that the menu indicators are flashing. The user program number will appear in the PROGRAM No. display, and "P- - -" will appear in the menu display. <p>Press the Δ or ∇ key to select the user program number.</p> <p style="text-align: right;">4469Q</p>
<p>2</p>	<p>First, set the program number.</p> 	<p>Press the Δ or ∇ key to set the user program number to be recorded.</p> <p>NOTE: Select a program number that is recorded in the internal memory. You cannot specify program numbers on removable media.</p> <p style="text-align: right;">4966Q</p>
<p>3</p>	<p>Next, set the X-scale.</p>  <p>X-SCALE indicator flashes</p>	<p>Press the SELECT key.</p>  <p>Press the Δ or ∇ key to set the X-scale to be recorded.</p> <p style="text-align: right;">4470Q</p>
<p>4</p>	<p>Next, set the Y-scale.</p>  <p>Y-SCALE indicator flashes</p>	<p>Press the SELECT key.</p>  <p>Press the Δ or ∇ key to set the Y-scale to be recorded.</p> <p style="text-align: right;">4472Q</p>
<p>5</p>	<p>Next, set the sewing speed.</p>  <p>SPEED indicator flashes</p>	<p>Press the SELECT key.</p>  <p>Press the Δ or ∇ key to set the sewing speed to be recorded.</p> <p style="text-align: right;">4474Q</p>

<p>6</p>	<p>Next, set the intermittent presser foot height.</p>  <p>THREAD/CLAMP indicator flashes</p>	<p>Press the SELECT key.</p>  <p>Press the ▲ or ▼ key to set the intermittent presser foot height to be recorded.</p> <p>4969Q</p>
<p>7</p>	 <p>TEST indicator illuminates, MENU indicator flashes</p>	<p>Press the SELECT key.</p>  <ul style="list-style-type: none"> • If setting further user programs, select the user program number and then repeat steps 2 to 7. <p>4970Q</p>
<p>8</p>	 <p>TEST indicator switches off, MENU indicator illuminates</p>	<p>Press the TEST key.</p>  <p>This completes the recording of a user program.</p> <ul style="list-style-type: none"> • The user program number will flash in the PROGRAM No. display, and the sewing machine will switch to home position detection standby. <p>4971Q</p>

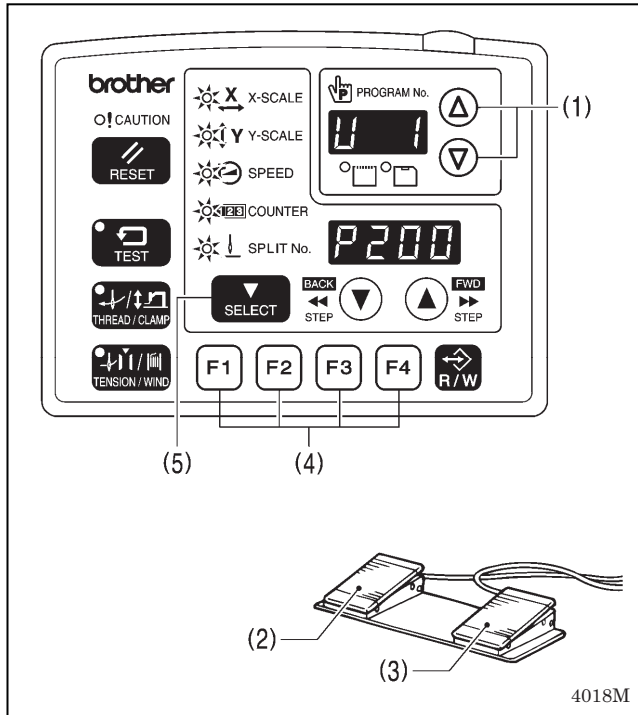

6. USING THE OPERATION PANEL (ADVANCED OPERATIONS)

<Setting method>



- Press the Δ or ∇ key (1) to select the user program number that you would like to use.
 - If the user program number is flashing, depress the work clamp switch (2) to lower the work clamp, and then depress the start switch (3). (The work clamp will move to the sewing start position.)
 - User programs U1 to U10 can be selected directly using function keys F1 to F4 (4). (Refer to "6-9. Direct selection".)
- Check that the needle drop position is correct, and then start sewing. (Refer to "5-6 Checking the sewing pattern".)
 - If you press the SELECT key (5), you can check the settings for the displayed user program (such as X-scale, Y-scale and sewing speed).







<Clearing method>

<p>1</p>	<p>TEST indicator illuminates, MENU indicator flashes</p>	<p>While pressing the TEST key, press the SELECT key</p>   <ul style="list-style-type: none"> Switch to user program recording mode. Check that the menu indicators are flashing. The user program number will appear in the PROGRAM No. display, and the program number will appear in the menu display. <p>Press the Δ or ∇ key (1) to select the user program number that you would like to clear.</p> <p style="text-align: right;">4970Q</p>
<p>2</p>	 <p>Clearing all user programs</p>	<p>Press the RESET key.</p> <ul style="list-style-type: none"> The buzzer will sound and the user program with the number selected will be cleared. <p>NOTE: If a cleared user program has been stored as part of a cycle program, the step that involves that user program will become blank. The cycle program itself will not be cleared.</p> <p>Press and hold the RESET key for 2 seconds or more.</p> <ul style="list-style-type: none"> The buzzer will sound and all user programs will be cleared. <p>NOTE: If any cycle programs have been memorized, all of the memorized cycle programs will also be cleared.</p>

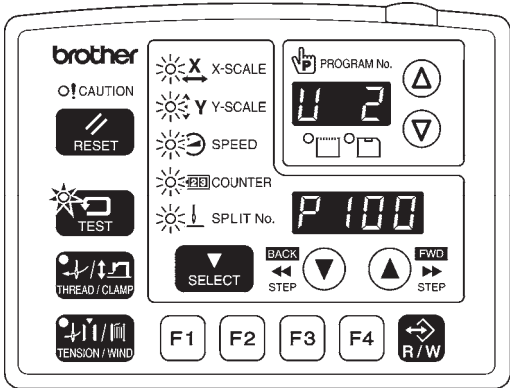

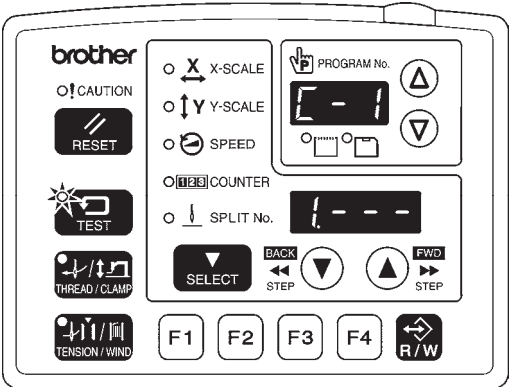
6-8. Using cycle programs

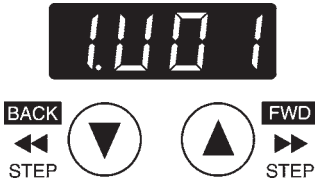
Sewing patterns that have been recorded in user programs can be recorded in up to nine cycle programs (C-1 to C-9). One cycle program can contain up to a maximum of fifteen steps. When sewing the sewing patterns in numerical order, it can be useful to record them in a cycle program beforehand. **Cycle programs are enabled when memory switch nos. 400 and 401 are set to "ON".**

<Recording method>

<p>1</p>	<p>Switch to user program recording mode.</p>  <p>TEST indicator illuminates, MENU indicator flashes</p>	<p>While pressing the TEST key, press the SELECT key.</p>  <ul style="list-style-type: none"> • Check that the menu indicators are flashing. • The user program number will appear in the PROGRAM No. display, and the program number will appear in the menu display. <p>Record the sewing pattern that you would like to use in a cycle program into a user program.</p> <p style="text-align: right;">4973Q</p>
<p>2</p>	<p>Switch to cycle program recording mode, and select the cycle program number.</p>  <p>MENU indicator switches off</p>	<p>Press a function key from F1 to F4.</p>  <ul style="list-style-type: none"> • The cycle program number (C-1 to C-4) will appear in the PROGRAM No. display, and "1.---" will appear in the menu display. <p>Press the function key (F1 to F4) or press the Δ or ∇ key to select the cycle program number.</p> <p style="text-align: right;">4428Q</p>
<p>3</p>	<p>Set step 1.</p> 	<p>Press the Δ or ∇ key to select the user program number that you would like to record.</p> <p>Press the SELECT key.</p>  <p style="text-align: right;">4444Q</p>
<p>4 Set the rest of the steps in the same way from step 2 onward. From step 9 onward, "A.---", "b.---", "c.---", "d.---", "E.---" and "F.---" will be displayed.</p> <p>If you would like to return to a previous step during the setting procedure <For cycle programs C-1 to C-4></p> <ol style="list-style-type: none"> 1. Press the respective function key from F1 to F4 to return to the display for step 1. 2. Press the SELECT key until the desired step is reached. <p><For cycle programs C-5 to C-9></p> <ol style="list-style-type: none"> 1. Press the Δ or ∇ key to switch the cycle program number. 2. Select the desired cycle program number again, and then press the SELECT key until the desired step is reached. 		

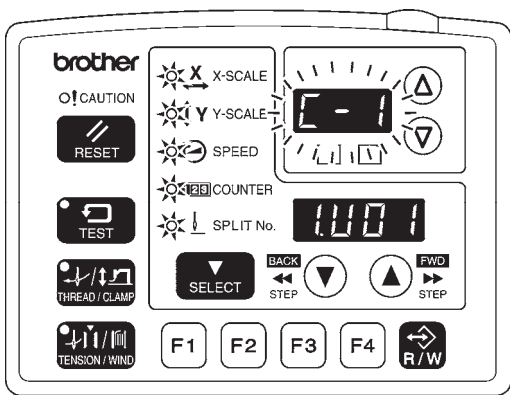
6. USING THE OPERATION PANEL (ADVANCED OPERATIONS)

5	To record another cycle program, repeat steps 2 to 4.
6	<p>End cycle program recording mode.</p> <p style="text-align: right;">Press the TEST key.</p> <div style="display: flex; justify-content: space-between; align-items: center;"> <div style="width: 45%;">  <p style="text-align: center;">TEST indicator switches off, MENU indicator illuminates</p> </div> <div style="width: 45%; text-align: center;">  <p>This completes the recording of cycle programs.</p> <ul style="list-style-type: none"> The cycle program number will flash in the PROGRAM No. display, and the sewing machine will switch to home position detection standby. </div> </div>

4439Q

<Setting method>

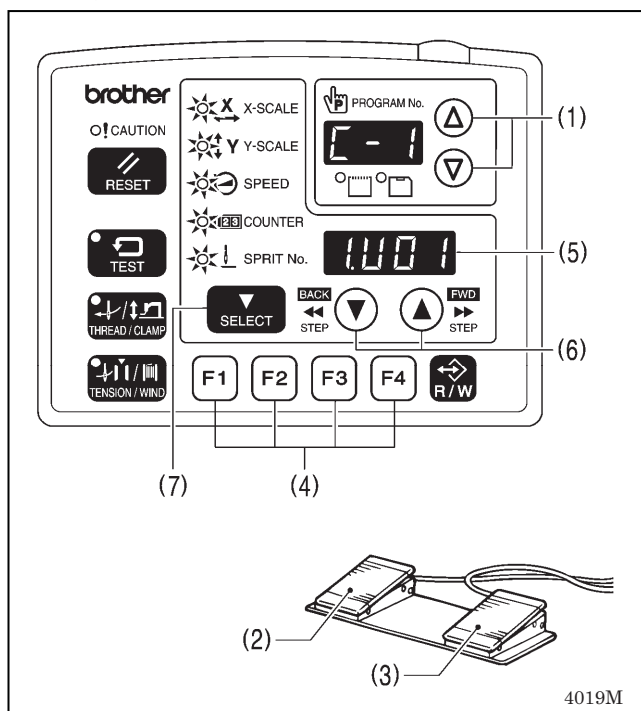





- Press the Δ or ∇ key (1) to select the cycle program number that you would like to use.
 - If the cycle program number is flashing, depress the work clamp switch (2) to lower the work clamp, and then depress the start switch (3). (The work clamp will move to the sewing start position.)
 - The cycle program number can be selected directly by pressing function keys F1 to F4 (4). (Refer to "6-9. Direct selection".)
- Check that the needle drop position is correct, and then start sewing. (Refer to "5-6 Checking the sewing pattern".)
- The recorded user program will be sewn step by step, and when the final step is complete, the menu display (5) will return to showing step 1.

- If you press the \blacktriangle or \blacktriangledown key (6), you can return to the previous step or skip to the next step respectively.
- If you press the SELECT key (7), you can check the details (such as X-scale, Y-scale and sewing speed) of the user program for the displayed step. The setting cannot be changed at this time.

NOTE:

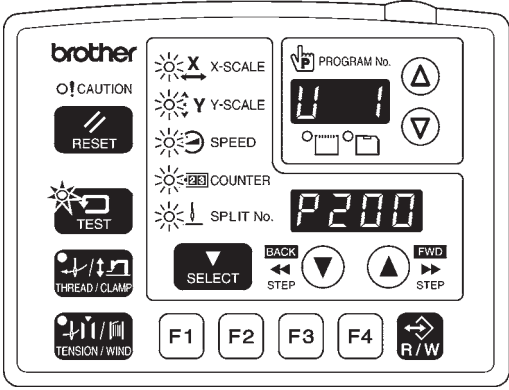
If cycle program sewing mode is active (when memory switch no. 401 is "ON") but no cycle programs have been recorded, the user programs will be sewn in numeric order. "C-0" will appear in the PROGRAM No. display at this time.

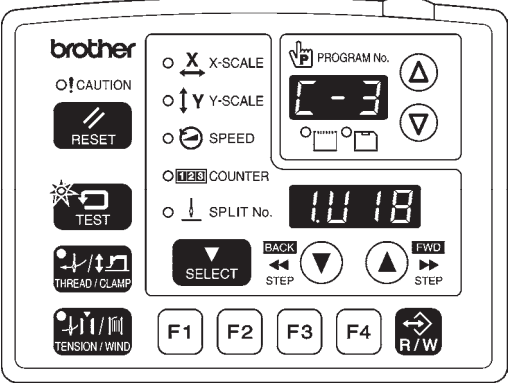
<Clearing method>

1		<p>While pressing the TEST key, press the SELECT key.</p> <div style="display: flex; justify-content: space-around; align-items: center;"> <div style="border: 1px solid black; padding: 5px; background-color: #333; color: white; text-align: center; width: 40px; height: 40px; border-radius: 5px;">  </div> <div style="border: 1px solid black; padding: 5px; background-color: #333; color: white; text-align: center; width: 40px; height: 40px; border-radius: 5px;">  </div> </div> <ul style="list-style-type: none"> Switch to user program recording mode. Check that the menu indicators are flashing.
TEST indicator illuminates, MENU indicator flashes 4970Q		
2		<p>Press a function key from F1 to F4.</p> <div style="display: flex; justify-content: center; gap: 10px; margin: 10px 0;"> <div style="border: 1px solid black; padding: 5px; background-color: #ccc; text-align: center; width: 40px; height: 40px; border-radius: 5px;">F1</div> <div style="border: 1px solid black; padding: 5px; background-color: #ccc; text-align: center; width: 40px; height: 40px; border-radius: 5px;">F2</div> <div style="border: 1px solid black; padding: 5px; background-color: #ccc; text-align: center; width: 40px; height: 40px; border-radius: 5px;">F3</div> <div style="border: 1px solid black; padding: 5px; background-color: #ccc; text-align: center; width: 40px; height: 40px; border-radius: 5px;">F4</div> </div> <ul style="list-style-type: none"> Switch to cycle program recording mode. <p>Press the function key (F1 to F4) or press the Δ or ∇ key to select the cycle program number to clear.</p>
MENU indicator switches off 4450Q		
3		<p>Press the RESET key.</p> <ul style="list-style-type: none"> The buzzer will sound and the cycle program with the number selected will be cleared. <div style="border: 1px solid black; padding: 10px; margin: 10px 0;"> <p>Clearing all cycle programs Press and hold the RESET key for 2 seconds or more.</p> <ul style="list-style-type: none"> The buzzer will sound and the all cycle programs will be cleared. </div>
<p>NOTE: If you clear all user programs after any cycle programs have been recorded, all recorded cycle programs will also be cleared.</p>		

6-9. Direct selection (combination table)

You can use the function keys to directly select user program numbers and cycle program numbers.

U1 to U4 and C-1 to C-4 can be selected using function keys F1 to F4.

U5 to U10 and C-5 to C-9 can be selected by simultaneously pressing combinations of function keys F1 to F4 (addition).

<p>U5/C-5</p> <div style="display: flex; justify-content: space-around; align-items: center; margin: 10px 0;"> <div style="border: 1px solid black; padding: 5px; background-color: #ccc; text-align: center; width: 40px; height: 40px; border-radius: 5px;">F1</div> <div style="font-size: 24px;">+</div> <div style="border: 1px solid black; padding: 5px; background-color: #ccc; text-align: center; width: 40px; height: 40px; border-radius: 5px;">F4</div> </div> <p style="font-size: 24px; margin: 5px 0;">Or</p> <div style="display: flex; justify-content: space-around; align-items: center; margin: 10px 0;"> <div style="border: 1px solid black; padding: 5px; background-color: #ccc; text-align: center; width: 40px; height: 40px; border-radius: 5px;">F2</div> <div style="font-size: 24px;">+</div> <div style="border: 1px solid black; padding: 5px; background-color: #ccc; text-align: center; width: 40px; height: 40px; border-radius: 5px;">F3</div> </div>	<p>U6/C-6</p> <div style="display: flex; justify-content: space-around; align-items: center; margin: 10px 0;"> <div style="border: 1px solid black; padding: 5px; background-color: #ccc; text-align: center; width: 40px; height: 40px; border-radius: 5px;">F2</div> <div style="font-size: 24px;">+</div> <div style="border: 1px solid black; padding: 5px; background-color: #ccc; text-align: center; width: 40px; height: 40px; border-radius: 5px;">F4</div> </div> <p style="font-size: 24px; margin: 5px 0;">Or</p> <div style="display: flex; justify-content: space-around; align-items: center; margin: 10px 0;"> <div style="border: 1px solid black; padding: 5px; background-color: #ccc; text-align: center; width: 40px; height: 40px; border-radius: 5px;">F1</div> <div style="font-size: 24px;">+</div> <div style="border: 1px solid black; padding: 5px; background-color: #ccc; text-align: center; width: 40px; height: 40px; border-radius: 5px;">F2</div> <div style="font-size: 24px;">+</div> <div style="border: 1px solid black; padding: 5px; background-color: #ccc; text-align: center; width: 40px; height: 40px; border-radius: 5px;">F3</div> </div>	<p>U7/C-7</p> <div style="display: flex; justify-content: space-around; align-items: center; margin: 10px 0;"> <div style="border: 1px solid black; padding: 5px; background-color: #ccc; text-align: center; width: 40px; height: 40px; border-radius: 5px;">F3</div> <div style="font-size: 24px;">+</div> <div style="border: 1px solid black; padding: 5px; background-color: #ccc; text-align: center; width: 40px; height: 40px; border-radius: 5px;">F4</div> </div> <p style="font-size: 24px; margin: 5px 0;">Or</p> <div style="display: flex; justify-content: space-around; align-items: center; margin: 10px 0;"> <div style="border: 1px solid black; padding: 5px; background-color: #ccc; text-align: center; width: 40px; height: 40px; border-radius: 5px;">F1</div> <div style="font-size: 24px;">+</div> <div style="border: 1px solid black; padding: 5px; background-color: #ccc; text-align: center; width: 40px; height: 40px; border-radius: 5px;">F2</div> <div style="font-size: 24px;">+</div> <div style="border: 1px solid black; padding: 5px; background-color: #ccc; text-align: center; width: 40px; height: 40px; border-radius: 5px;">F4</div> </div>
<p>U8/C-8</p> <div style="display: flex; justify-content: space-around; align-items: center; margin: 10px 0;"> <div style="border: 1px solid black; padding: 5px; background-color: #ccc; text-align: center; width: 40px; height: 40px; border-radius: 5px;">F1</div> <div style="font-size: 24px;">+</div> <div style="border: 1px solid black; padding: 5px; background-color: #ccc; text-align: center; width: 40px; height: 40px; border-radius: 5px;">F3</div> <div style="font-size: 24px;">+</div> <div style="border: 1px solid black; padding: 5px; background-color: #ccc; text-align: center; width: 40px; height: 40px; border-radius: 5px;">F4</div> </div>	<p>U9/C-9</p> <div style="display: flex; justify-content: space-around; align-items: center; margin: 10px 0;"> <div style="border: 1px solid black; padding: 5px; background-color: #ccc; text-align: center; width: 40px; height: 40px; border-radius: 5px;">F2</div> <div style="font-size: 24px;">+</div> <div style="border: 1px solid black; padding: 5px; background-color: #ccc; text-align: center; width: 40px; height: 40px; border-radius: 5px;">F3</div> <div style="font-size: 24px;">+</div> <div style="border: 1px solid black; padding: 5px; background-color: #ccc; text-align: center; width: 40px; height: 40px; border-radius: 5px;">F4</div> </div>	<p>U10</p> <div style="display: flex; justify-content: space-around; align-items: center; margin: 10px 0;"> <div style="border: 1px solid black; padding: 5px; background-color: #ccc; text-align: center; width: 40px; height: 40px; border-radius: 5px;">F1</div> <div style="font-size: 24px;">+</div> <div style="border: 1px solid black; padding: 5px; background-color: #ccc; text-align: center; width: 40px; height: 40px; border-radius: 5px;">F2</div> <div style="font-size: 24px;">+</div> <div style="border: 1px solid black; padding: 5px; background-color: #ccc; text-align: center; width: 40px; height: 40px; border-radius: 5px;">F3</div> <div style="font-size: 24px;">+</div> <div style="border: 1px solid black; padding: 5px; background-color: #ccc; text-align: center; width: 40px; height: 40px; border-radius: 5px;">F4</div> </div>

6-10. X and Y parallel movement of sewing pattern

You can move the feed mechanism to the desired position to move an already-programmed sewing pattern in a parallel direction up, down or to the left or right.

<p>1</p>		<ol style="list-style-type: none"> 1. Press the Δ or ∇ key to select the program number. 2. Depress the work clamp switch (1) to lower the work clamp, and then depress the start switch (2). <ul style="list-style-type: none"> • The work clamp will move to the sewing start position.
<p>2</p>		<p>While pressing the TEST key, press the ∇ key.</p> <ul style="list-style-type: none"> • The parallel movement amount will appear in the menu display in units of mm.
<p>3</p>	<p>X-scale parallel movement mode Y-scale parallel movement mode</p> <p>4560Q</p> <p>4561Q</p>	<p>Press the SELECT key to switch between the X-SCALE indicator and Y-SCALE indicator flashing. Select either direction.</p> <p>The feed mechanism will move by 0.05 mm each time the Δ or ∇ key is pressed. (When the distance reaches 10 mm, the amount of movement will change to 0.1 mm.)</p> <ul style="list-style-type: none"> • When using X-scale parallel movement mode, the needle moves the corresponding distance to the right when the Δ key is pressed, and to the left when the ∇ key is pressed. • When using Y-scale parallel movement mode, the needle moves the corresponding distance backward when the Δ key is pressed, and forward when the ∇ key is pressed.
<p>4</p>	<p>End parallel movement mode</p> <p>TEST indicator switches off</p>	<p>Press the TEST key.</p>

NOTE:





- The feed mechanism will not move to a position that would move the sewing pattern outside the sewing area.
- If you change the program number, X-scale or Y-scale settings, the amount of movement recorded will be reset.
- In addition, the amount of movement will be reset if the power switch is turned off and then back on again. However, memory switch No. 465 is set to "ON", the amount of movement will be recorded and will not be reset. (Refer to the service manual for details on memory switch No. 465.)

6-11. Clearing memory data (reinitialization)

If the sewing machine stops operating normally, the cause may be that an incorrect memory setting may have been made by means of the memory switch, for instance. In such cases, normal operation may be restored if the memory data is reinitialized.

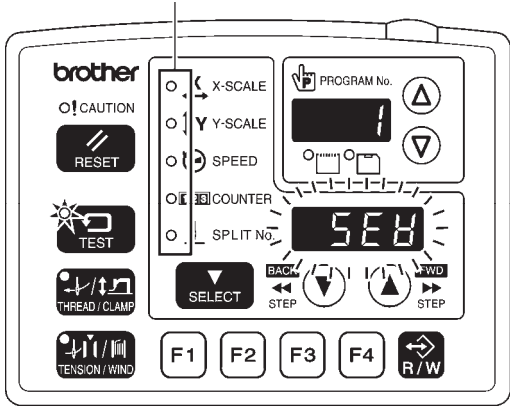
Parameter No.	Setting items	
1	[SEW]	Clearing all sewing programs
	[-***]	Clearing individual sewing programs
2	[MEM]	Reinitializing memory switches
3	[ALL]	Clearing or reinitializing all memory data (sewing programs, memory switches, user programs, cycle programs and expansion option output data)
4	[USE]	Clearing user programs and cycle programs
5	[EoP]	Clearing expansion option output data

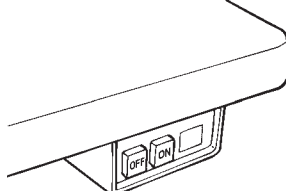
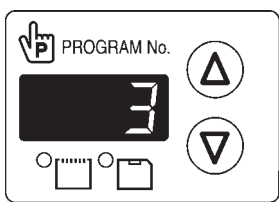
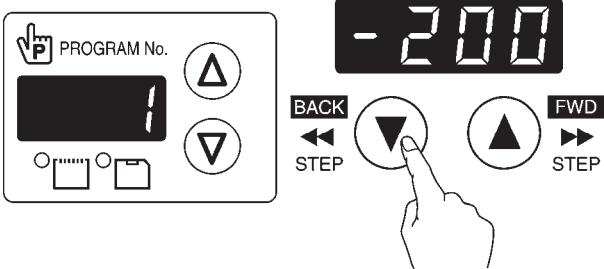
* Refer to the instruction manual for the programmer for details of expansion option output.

1	<p>All indicators switch off</p> 	<p>While holding down the RESET key, turn on the power switch. * Keep pressing the RESET key until the model name is displayed and the buzzer beeps once.</p>   <ul style="list-style-type: none"> The parameter number will appear in the PROGRAM No. display, and the setting details for that parameter will appear in the menu display.
<p>TEST indicator illuminates, MENU indicator switches off 4562Q 4421Q</p>		
2		<p>Press the Δ or ∇ key to select the parameter number that you would like to reinitialize.</p>
<p>Selecting individual sewing programs 4557Q</p>		
		<p>For parameter No. 1, press the ∇ key to change the display from " SEW" to "-***". (***) is the sewing program number.) Press the Δ or ∇ key to select the sewing program number that you would like to clear.</p>
<p>4563Q</p>		
3		<p>Press and hold the RESET key for 2 seconds or more.</p> <ul style="list-style-type: none"> A long beep will sound and the data for the selected item will be reinitialized. The setting details for only the initialized item will change from flashing to steadily illuminated.
4	<p>End data initialization mode</p>  <p>TEST indicator switches off</p>	<p>Press the TEST key.</p>

7. USING CF CARDS

7-1. Notes on handling CF cards (sold separately)

- Use a CF card with a memory capacity of 32, 64, 128, 256, 512 MB, 1GB or 2GB. (CF cards with a capacity of more than 2GB are not supported.)
- Do not disassemble or modify the CF card.
- Do not bend, drop or scratch CF cards or place heavy objects on top of them.
- Avoid contact with liquids such as water, oil, solvents or drinks.
- Use and store CF cards in locations that are free from strong static electricity and electrical interference.
- Do not use or store CF cards in places where they may be subject to vibrations or shocks, direct sunlight, high temperature or humidity or strong magnetic fields from equipment such as speakers, or places which are dusty from thread scraps, etc.
- Do not subject CF cards to shocks or impacts or remove them from the sewing machine while data is being loaded or written.
- The data on the CF cards may become lost or corrupted due to some malfunction or accident. It is recommended that you make a backup of important data.
- CF cards should only be removed after the power for the sewing machine has been turned off.
- CF cards are already formatted when they are purchased, and so you should not reformat them.
- The recommended CF cards are commercially-available ones from SanDisk or HAGIWARA SYS-COM. CF cards from other manufacturers can be used, but different formatting methods may mean that loading from or writing to such cards may not be possible.

For more information, refer to the documentation provided with the CF card.



- * This product is compatible with CF cards that have been formatted using the FAT16 method. Cards that have been formatted using the FAT32 method cannot be used.
- * CF™ is a trademark of SanDisk Corporation.
- * Company names and product names appearing in this manual are trademarks or registered trademarks of the respective owners. However, no TM or other similar symbols appear in the main text of this manual.

7-2. Structure of a CF card folder

\BROTHER\ISM\ISMSYS\ISM02MN.MOT	: Control program
\BROTHER\ISM\ISMDB00\ISMMSW.SEW	: Memory switch data
*1 \ISMUPG.SEW	: User program data
\ISMS0100.SEW	: Sewing data P No. = 100
\ISMS0101.SEW	: Sewing data P No. = 101
\ISMS0102.SEW	: Sewing data P No. = 102
⋮	⋮

- *1 The underlined portion of the name of the \BROTHER\ISM\ISMDB00 folder for sewing data can be changed by changing the setting for memory switch No. 752 in order to change the folder name. Change the folder name if you would like to store sewing data for different sewing machines on a single CF card. (Refer to the service manual for details on memory switch No. 752.)

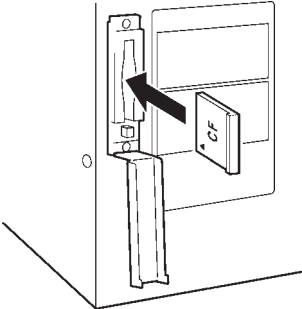
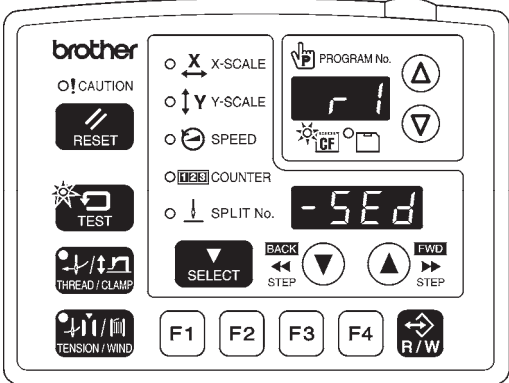
7-3. Data read/write mode

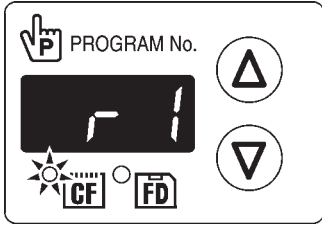
1		<p>With the power turned off, insert the CF card into the CF slot.</p> <p>NOTE:</p> <ul style="list-style-type: none"> • Make sure the CF card is facing the correct way. • Always be sure to keep the cover closed except when inserting and removing the CF card. If this is not done, dust may get inside and cause problems with operation. • If no valid data can be found, the CF media indicator will not illuminate.
2	Turn on the power switch.	
3	<p>Switch to data read/write mode.</p>  <p>TEST indicator and CF media indicator illuminate</p>	<p>While pressing the TEST key, press the R/W key.</p>  <ul style="list-style-type: none"> • The mode number will appear in the PROGRAM No. display, and the setting details for that mode will appear in the menu display. • The initial mode is sewing data reading mode. (Refer to the read/write mode list)
4		Press the Δ or ∇ key to select the mode.

[Read/write mode list]





PROGRAM No. display	Menu display	Setting items
r 1	[-SEd]	Sewing data is read from the CF card. (*1)
w 2	[SEd-]	Sewing data is written to the CF card.
r 3	[-MEM]	Memory switch settings are read from the CF card.
w 4	[MEM-]	Memory switch settings are written to the CF card.
r 5	[-UPG]	User programs are read from the CF card.
w 6	[UPG-]	User programs are written to the CF card.
r 7	[-SyS]	Control programs are read from the CF card and used to update the firmware version.
w 8	[LoG-]	Error log data is written to the CF card.
r 9	[-Fdd]	Sewing data is read from the floppy disk. (*2) (*3)
w 10	[Fdd-]	Sewing data is written to the floppy disk. (*2)
r 11	[-EoP]	Expansion option output (*4) data is read from the CF card.
w 12	[EoP-]	Expansion option output data is written to the CF card.
r 13	[oPFd]	Expansion option output data is read from the floppy disk. (*2)
r 14	[-EoP]	Expansion option output data for older models is read from the CF card. (*5)

(Continued on next page)



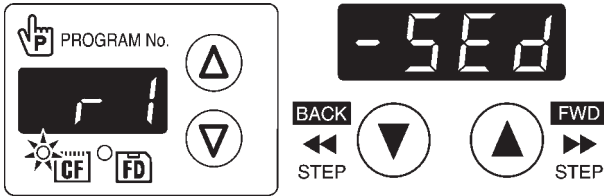
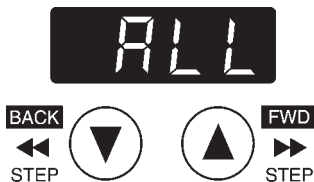

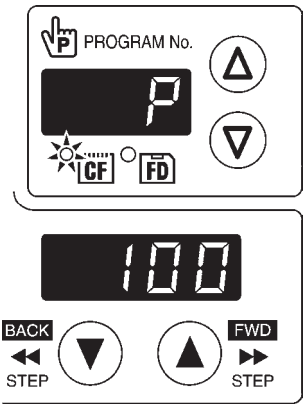
7. USING CF CARDS

- *1 The sewing data that can be used with this sewing machine is data that has been created for the BAS-300G series.
- *2 Only valid when using an optional floppy disk drive.
- *3 Sewing data for the BAS-300 series, BAS-300A series and BAS-300E/F series can be read.
- *4 Refer to the instruction manual for the programmer for details of expansion option output.
- *5 Can be selected when memory switch No. 755 = ON.
Save the expansion option output data (BAS900.SEQ) in the \BROTHER\ISM\ISMDB00 folder.

7-3-1. Reading all sewing data from the CF card at once

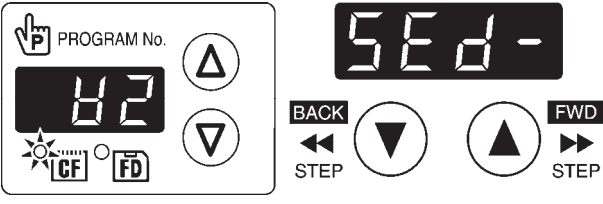
1		<p>Select the [r 1] data read/write mode.</p> <p style="text-align: right;">4576Q</p>
2		<p>Press the R/W key.</p>  <ul style="list-style-type: none"> • [-SEd] will change to [ALL]. * If you press the ▲ or ▼ key to select the program numbers that you would like to read and then continue to carry out the following procedure, you can read the selected sewing data in separate lots. <p style="text-align: right;">4577Q</p>
3		<p>Press the R/W key.</p>  <ul style="list-style-type: none"> • The buzzer will sound and all sewing data will be loaded from the CF card and copied into the sewing machine's internal memory. • The program numbers that have been read will appear in the menu display. * If there is a large volume of data in the CF card, it will take some time for all of it to be read. To halt the reading of data, press the STOP switch. If you then press the RESET key, the display will change back to [ALL]. <p style="text-align: center;">Loading</p> <p style="text-align: right;">4976Q</p>
4	<p>End data read/write mode</p>  <p style="text-align: center;">TEST indicator switches off</p>	<p>Press the TEST key. Turn off the power switch, remove the CF card, and then close the cover of the CF slot.</p>

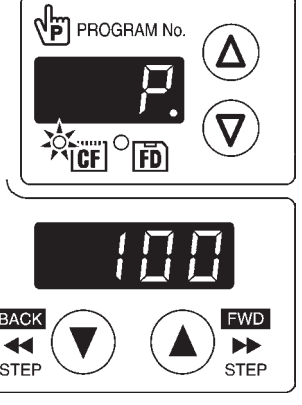
7-3-2. Writing all sewing data to the CF card at once

1		<p>Select the [w 2] data read/write mode.</p> <p style="text-align: right;">4578Q</p>
2		<p>Press the R/W key.</p>  <ul style="list-style-type: none"> • [SEd-] will change to [ALL]. * If you press the ▲ or ▼ key to select the program numbers that you would like to write and then continue to carry out the following procedure, you can write the selected sewing data in separate lots. <p style="text-align: right;">4577Q</p>
3		<p>Press the R/W key.</p>  <ul style="list-style-type: none"> • The buzzer will sound and the all sewing data will be copied from the internal memory onto the CF card. • The program numbers that have been written will appear in the menu display. * If there is a large volume of data in the internal memory, it will take some time for all of it to be written. To halt the writing of data, press the STOP switch. If you then press the RESET key, the display will change back to [ALL]. <p style="text-align: center;">Writing</p> <p style="text-align: right;">4977Q</p>
4	<p>End data read/write mode</p>  <p style="text-align: center;">TEST indicator switches off</p>	<p>Press the TEST key. Turn off the power switch, remove the CF card, and then close the cover of the CF slot.</p>

Refer to the service manual for details on other read/write modes.

8. SEWING

! CAUTION



Turn off the power switch at the following times.

If the foot switch is depressed by mistake, the sewing machine might start operating and injury could result.

- When threading the needle
- When replacing the bobbin and needle
- When not using the machine and when leaving the machine unattended



Do not touch any of the moving parts or press any objects against the machine while sewing, as this may result in personal injury or damage to the machine.

8-1. Sewing

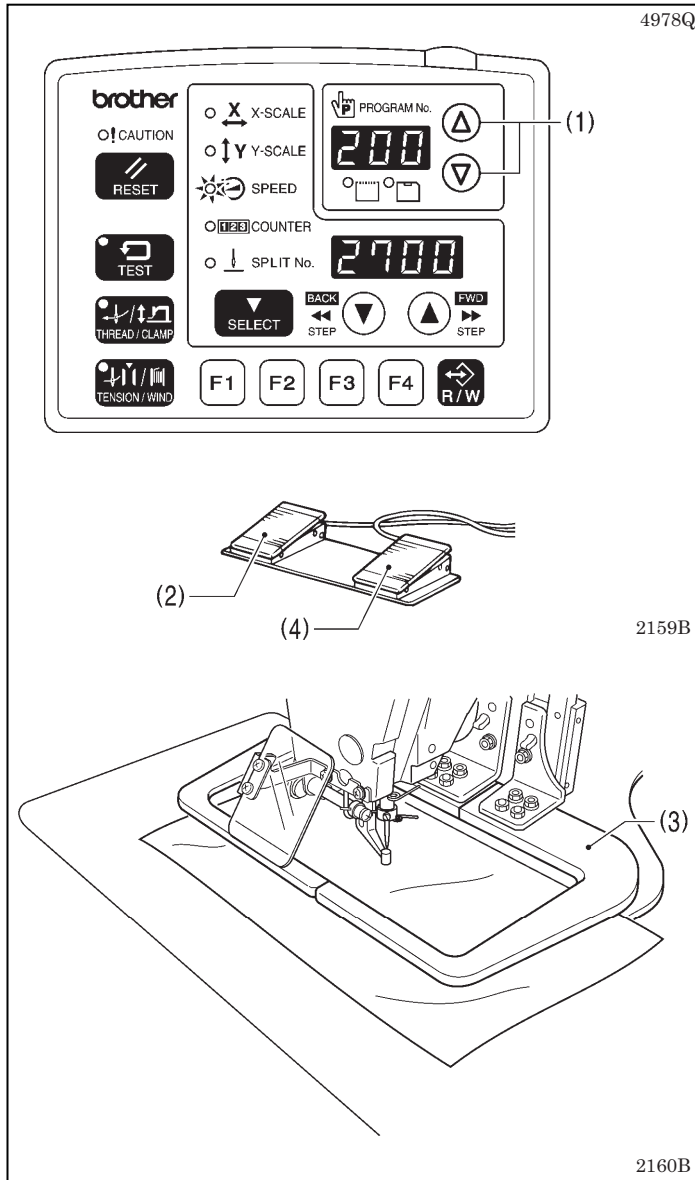

1. Turn on the power switch.
2. Press the Δ or ∇ key (1) to select the sewing program number that you would like to use.
 - * Refer to "5-2. Loading sewing data" for details on reading sewing data from a CF card.
3. Depress the work clamp switch (2) to lower the work clamp (3), and then depress the start switch (4).
 - The work clamp will move to the sewing start position.
 - Home position detection will be carried out immediately after the power switch is turned on.
4. Place the article to be sewn underneath the work clamp (3).
5. Depress the work clamp switch (2).
 - The work clamp (3) will drop.
6. Depress the start switch (4).
 - The sewing machine will start sewing.
7. When sewing is complete, the thread will be trimmed and the work clamp (3) will rise.

Use a work clamp and a feed plate which will hold the article securely so that it does not slip.

If using the standard work clamp and feed plate and the article being sewn is slipping, take measures to stop the work clamp and feed plate from being slippery.

8-2. Using the STOP switch

If you press the STOP switch (1) while sewing or test feeding is in progress, the CAUTION indicator (2) will illuminate and the sewing machine will stop immediately.

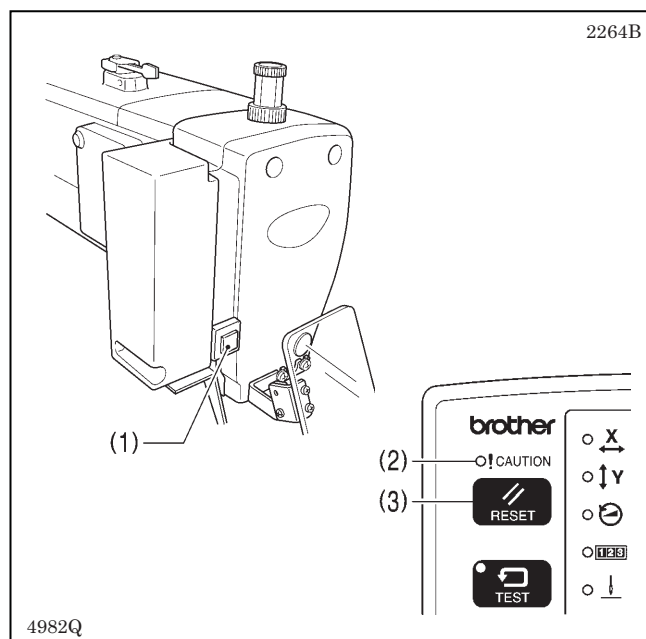

<Clearing>

1. Press the RESET key (3).
 - The thread will be trimmed, and then the CAUTION indicator (2) will switch off and the buzzer will stop sounding.
2. If you do not wish to continue sewing, press the RESET key (3) once more.
 - The program number will flash. Carry out preparation for the next sewing.

<Continuing sewing from a stopping point>

If you have pressed the STOP switch (1) at times such as if the thread breaks while sewing or the lower thread runs out, you can resume sewing from the point where the thread ran out.

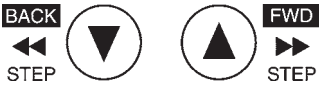
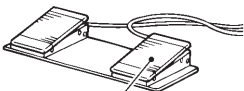
1		<p>Press the RESET key.</p> <ul style="list-style-type: none"> • The thread will be trimmed, and then the CAUTION indicator will switch off and the buzzer will stop sounding.
2		<p>Press the ▼ key to return to the position where sewing stopped.</p> <ul style="list-style-type: none"> • When you press the ▼ key, the feed mechanism will move backward one stitch at a time, and when you press the ▲ key, it will move forward one stitch at a time. (The feed will move quicker if you keep the key pressed down.)
3		<p>Depress the start switch (4).</p> <ul style="list-style-type: none"> • The sewing machine will start operating and sewing will start.

8-3. Using the thread wiper switch

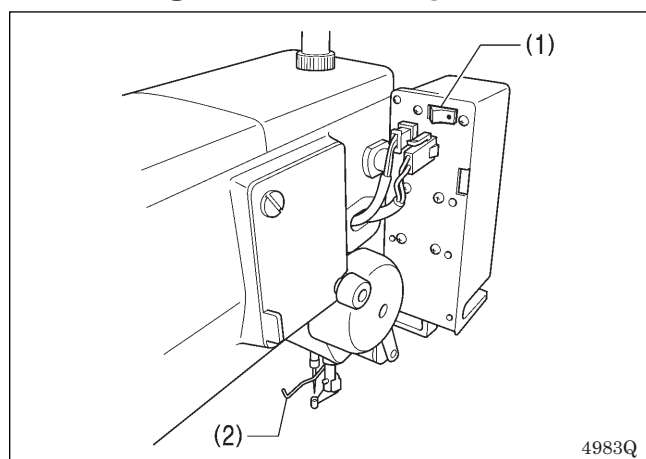

The thread wiper switch (1) can be used to turn the thread wiper (2) on and off.

9. CLEANING

CAUTION



Turn off the power switch before carrying out cleaning.
If the foot switch is depressed by mistake, the sewing machine might start operating and injury could result.



Be sure to wear protective goggles and gloves when handling the lubricating oil and grease, so that they do not get into your eyes or onto your skin. If the oil and grease get into your eyes or onto your skin, inflammation can result. Furthermore, do not drink or eat the lubricating oil or grease. They may cause diarrhea or vomiting. Keep the oil out of the reach of children.

9-1. Cleaning the rotary hook

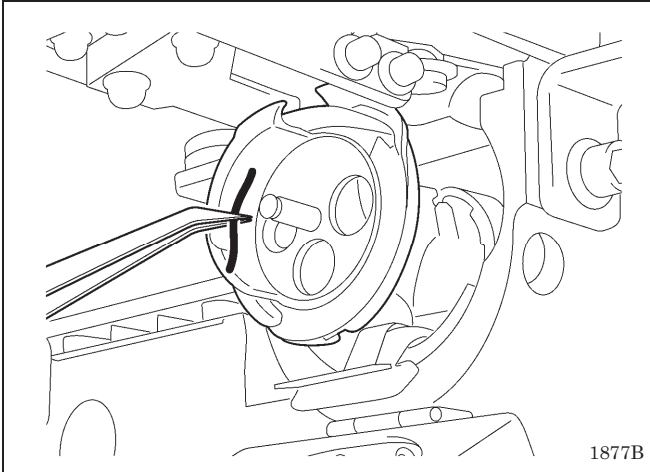

Remove the bobbin case, and then remove the thread scraps and lint from around the shuttle. Also wipe the bobbin to remove oil.

9-2. Cleaning the control box air inlet ports

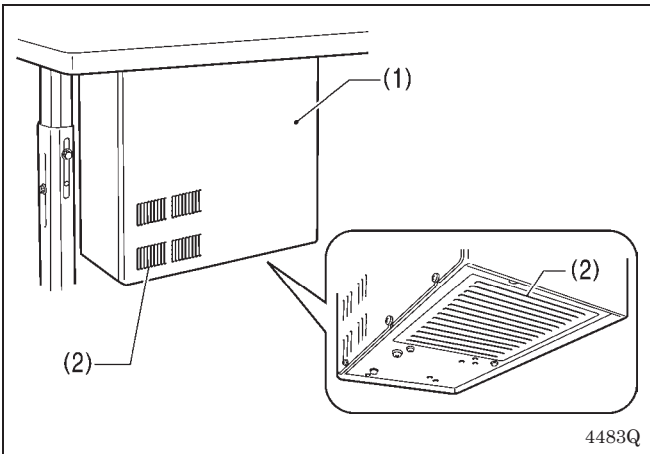

Use a vacuum cleaner to clean the filter in the air inlet ports (2) of the control box (1) at least once a month.

9-3. Draining the oil

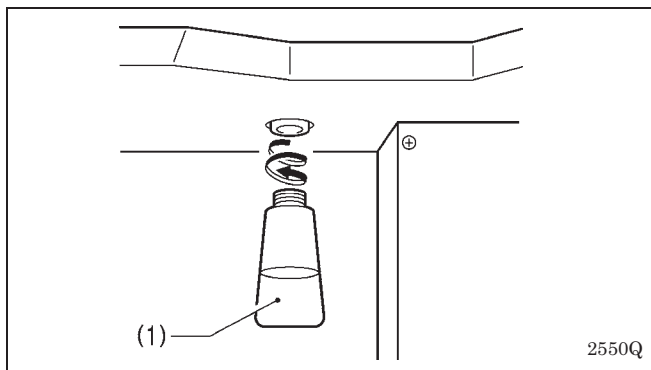

1. Remove and empty the waste oil tank (1) whenever it is full.
2. After emptying the waste oil tank (1), screw it back into its original position.

9-4. Cleaning the eye guard

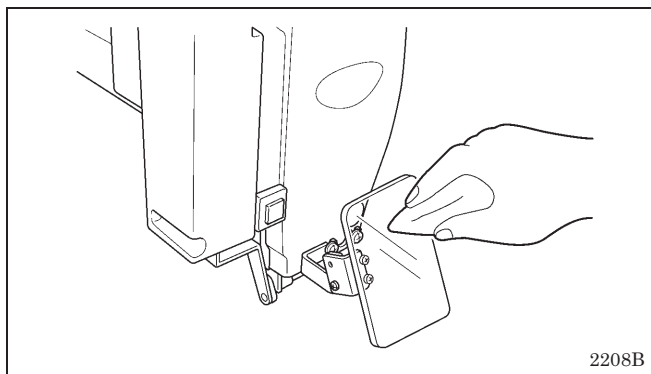

Wipe the eye guard clean with a soft cloth.

NOTE:

Do not use solvents such as kerosene or thinner to clean the eye guard.

9-5. Checking the needle

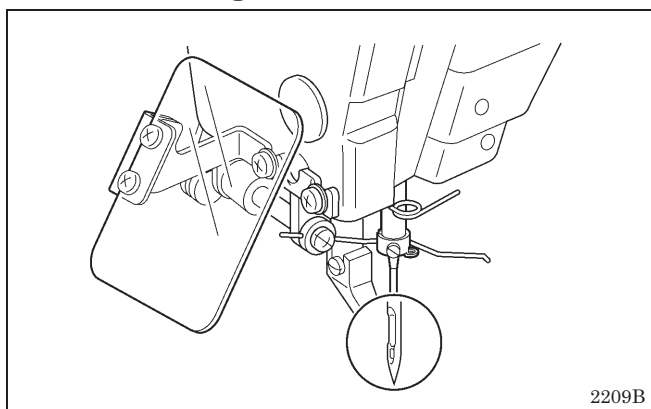

Always check that the tip of the needle is not broken and also that the needle is not bent before starting sewing.

9-6. Lubrication

Lubricate the sewing machine while referring to "3-14. Lubrication".

10. STANDARD ADJUSTMENTS

⚠ CAUTION

 Maintenance and inspection of the sewing machine should only be carried out by a qualified technician.

 Ask your Brother dealer or a qualified electrician to carry out any maintenance and inspection of the electrical system.

 Turn off the power switch and disconnect the power cord before carrying out the following operations. If the foot switch is depressed by mistake, the sewing machine might start operating and injury could result.

- Inspection, adjustment and maintenance
- Replacing consumable parts such as the rotary hook

 Hold the machine head with both hands when tilting it back or returning it to its original position.

In addition, do not apply excessive force when tilting back the machine head. The sewing machine may become unbalanced and fall down, and serious injury or damage to the sewing machine may result.

 If the power switch needs to be left on when carrying out some adjustment, be extremely careful to observe all safety precautions.

 If any safety devices have been removed, be absolutely sure to re-install them to their original positions and check that they operate correctly before using the machine.

10-1. Checking the machine head switch

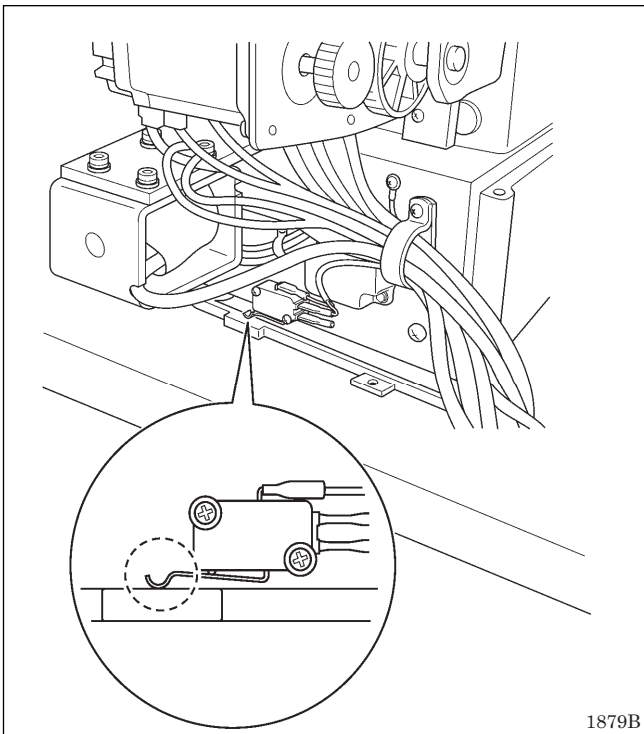

Check that the machine head switch is turned on as shown in the illustration.

NOTE:

If the machine head switch is not turned on, errors "E050", "E051" and "E055" will be generated.

10-2. Arm thread guide R

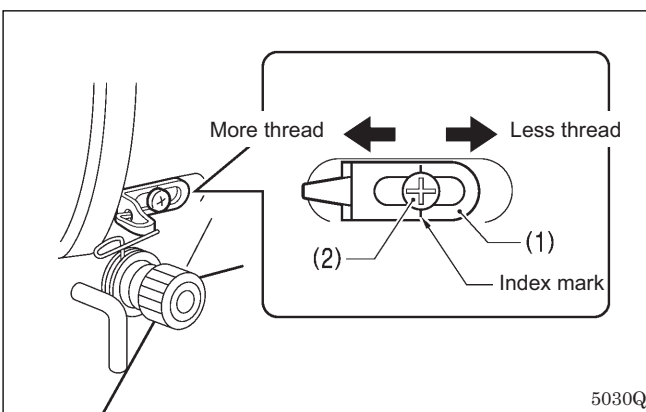

The standard position of arm thread guide R (1) is when the screw (2) is aligned with the index mark. Loosen the screw (2) and move arm thread guide R (1) to adjust.

- * When sewing heavy material, move arm thread guide R (1) to the left. (The thread take-up amount will become greater.)
- * When sewing light material, move arm thread guide R (1) to the right. (The thread take-up amount will become less.)

10-3. Thread take-up spring

Thread take-up spring height (mm)	7 – 10
Thread take-up spring tension (N)	1.0 – 1.2

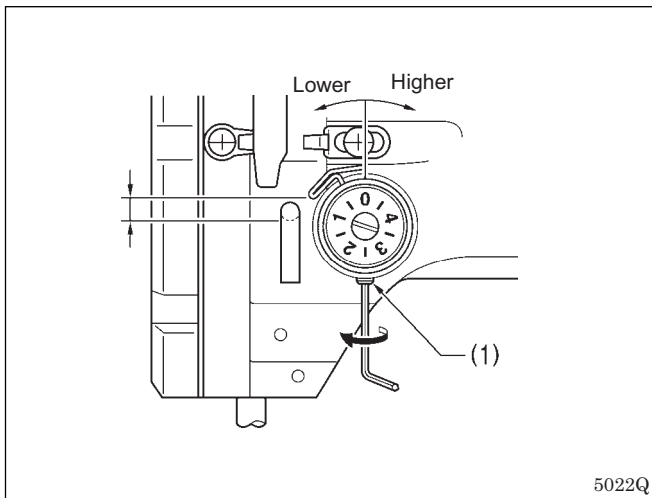

<Thread take-up spring height>

Loosen the set screw (1) and turn the adjuster to adjust.

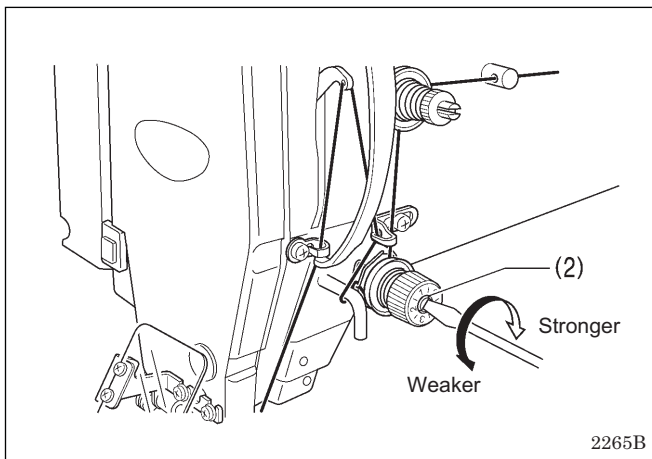

<Thread take-up spring tension>

Turn the tension stud (2) with a screwdriver to adjust the tension.

NOTE:

If the thread tension spring is not adjusted correctly, the upper thread trailing length will be uneven after thread trimming.

10-4. Adjusting the needle bar height

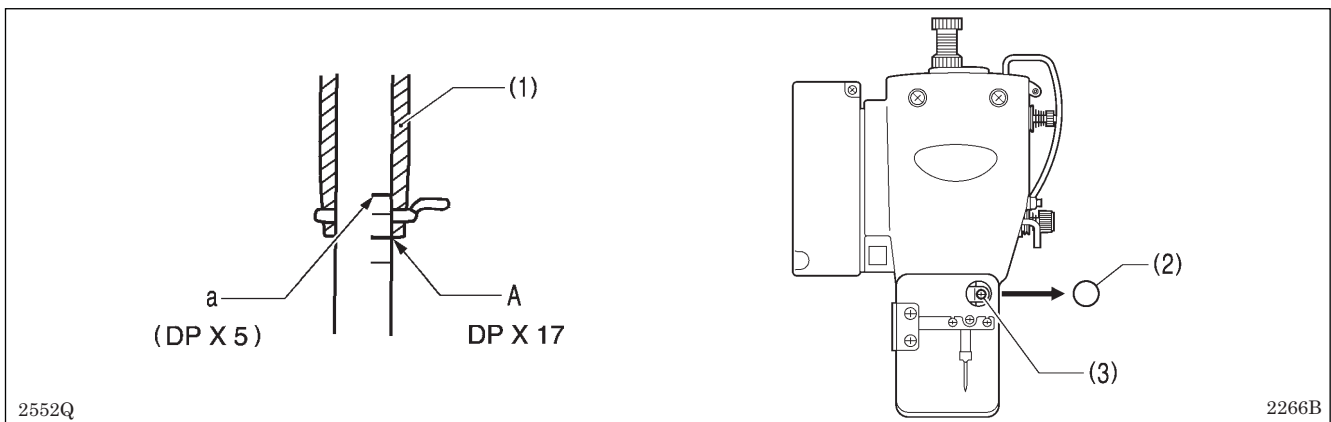

Turn the machine pulley to move the needle bar to the lowest position. Then remove the rubber plug (2), loosen the screw (3) and then move the needle bar up or down to adjust so that the second reference line from the bottom of the needle bar (reference line A) is aligned with the lower edge of the needle bar bush (1).

* If using a DP X 5 needle, use the highest reference line (reference line a).

10-5. Adjusting the needle bar lift amount

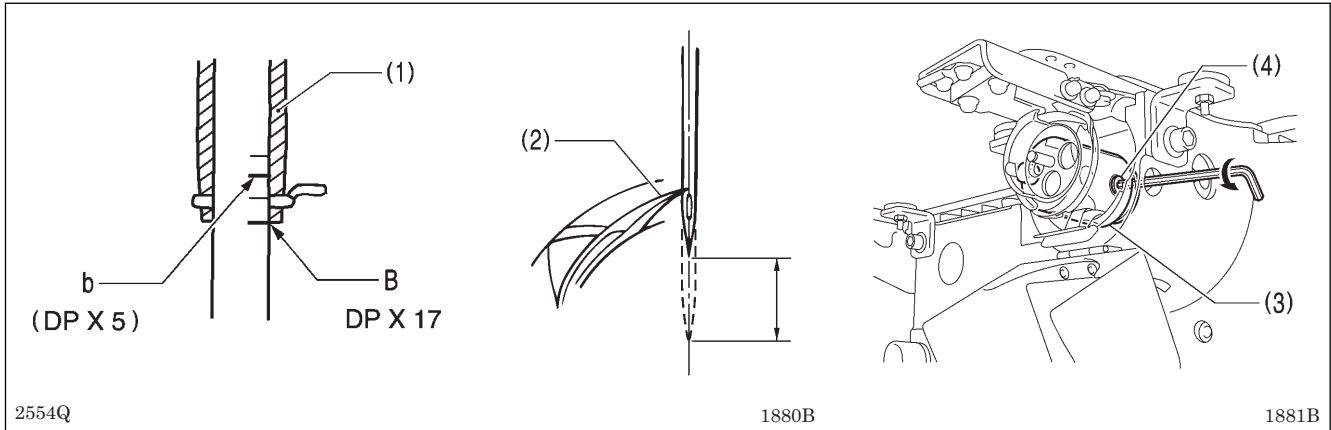

Turn the machine pulley to raise the needle bar from the lowest position until the lowest reference line on the needle bar (reference line B) is aligned with the lower edge of the needle bar bush (1), and then adjust the two set screws (4) of the rotary hook joint (3) so that the rotary hook tip (2) is aligned with the center of the needle.

* If using a DP X 5 needle, use the second reference line from the top of the needle bar (reference line b).

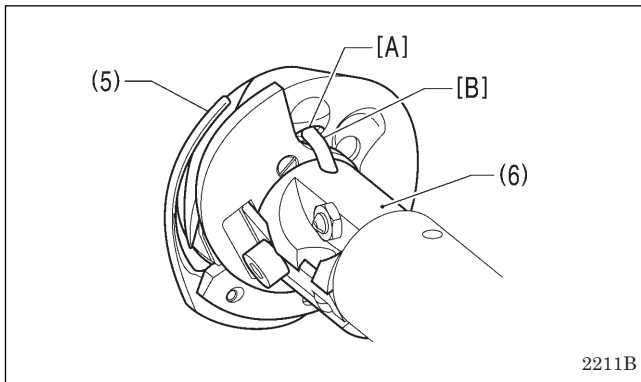

NOTE:

When installing the rotary hook joint, install using the set screws so that the oil inlet [A] in the rotary hook (5) is aligned with the oil inlet [B] in the rotary hook joint assembly (6).

10-6. Adjusting the needle guard

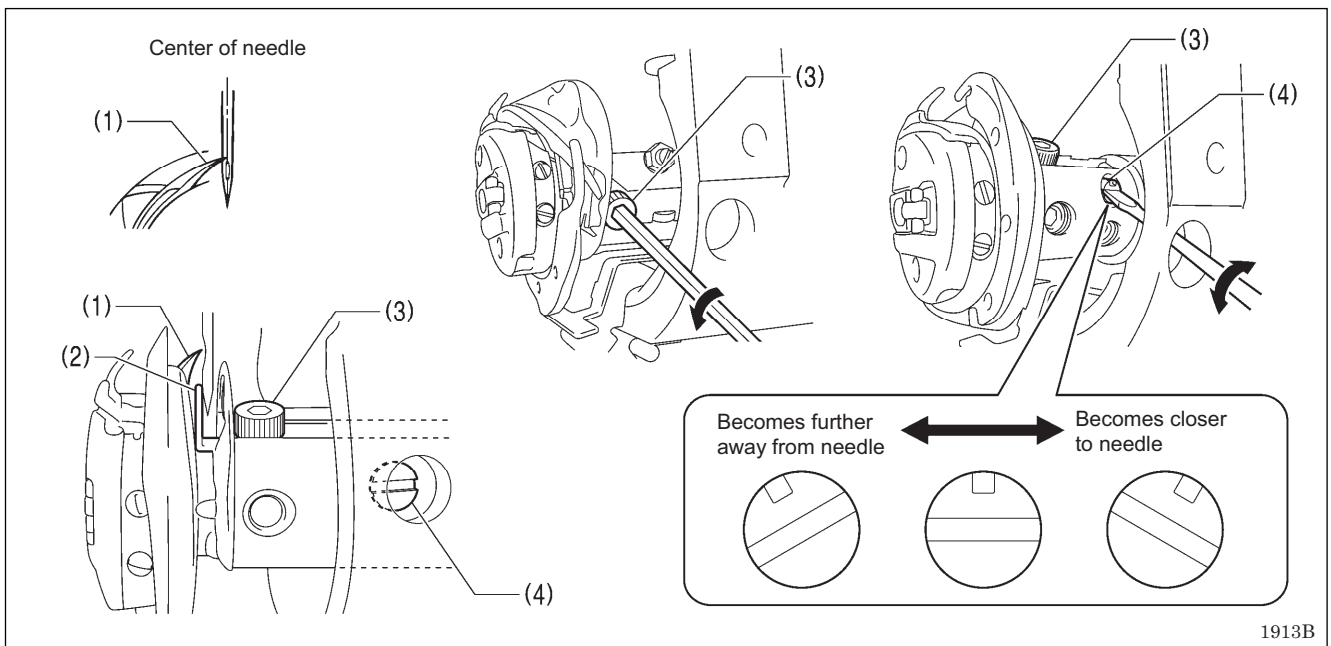

Turn the machine pulley to align the tip of the rotary hook (1) with the center of the needle, and then loosen the bolt (3) and turn the needle guard adjusting shaft (4) to adjust so that the needle guard (2) is touching the needle.

NOTE:

If it crosses the needle more than necessary, it will place a load on the needle, or it may cause poor thread tension.

Furthermore, if it does not cross the needle at all, the tip of the rotary hook (1) will interfere with the needle and skipped stitches may occur.

10-7. Adjusting the needle clearance

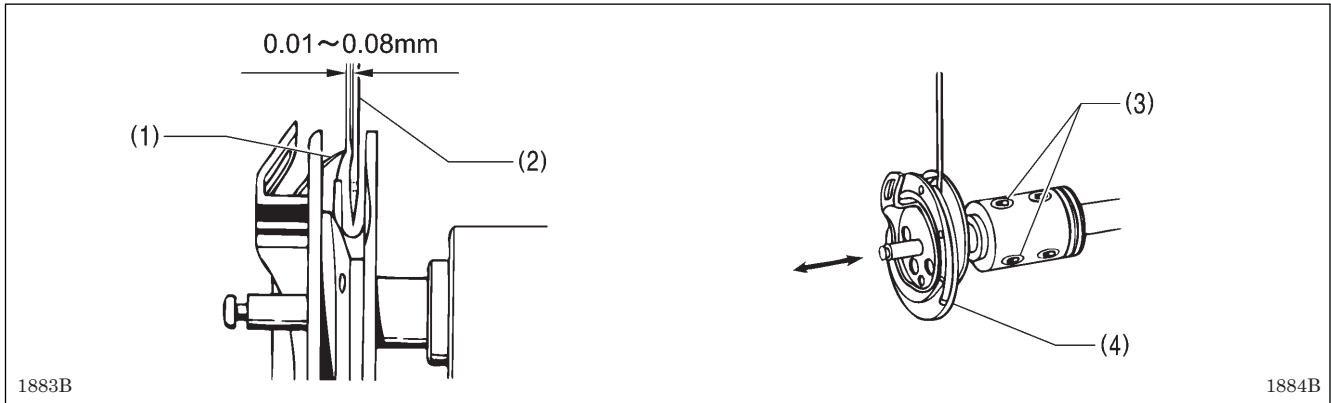

Turn the machine pulley to align the rotary hook tip (1) with the center of the needle (2), and then loosen the two set screws (3) and move the rotary hook (4) forward or back to adjust so that the clearance between the needle (2) and the rotary hook tip (1) is 0.01 – 0.08 mm.

10-8. Adjusting the inner rotary hook and hook stopper overlap

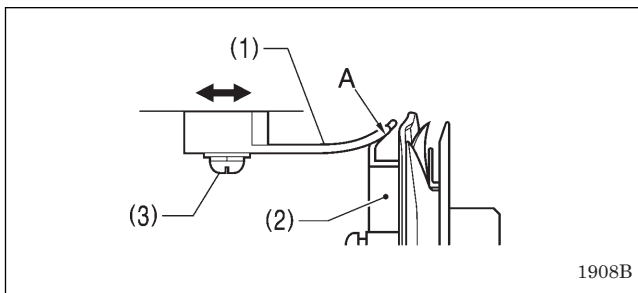

Loosen the two screws (3) to adjust so that the tip of the hook stopper (1) does not protrude past edge A of the inner rotary hook (2).

10-9. Rotary hook lubrication amount

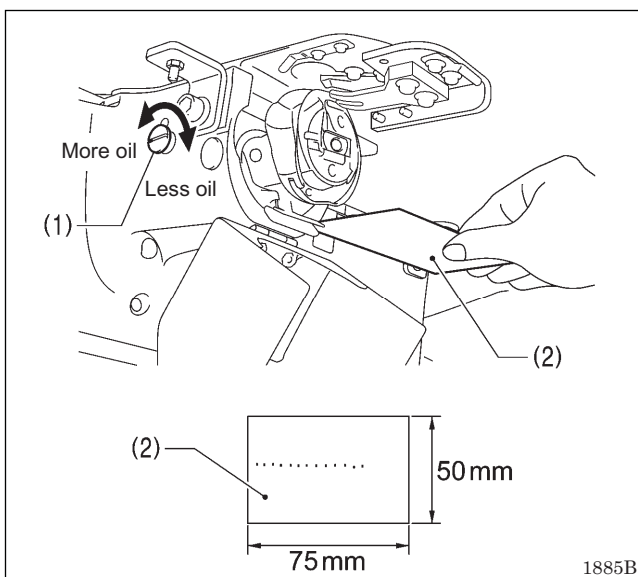

Turn the adjusting screw (1) to adjust the lubrication amount.

* Adjust so that approximately 10 drops of oil are released when the sewing machine is run at a speed of 2,700 sti/min for three cycles to sew about 150 stitches. Use Kraft paper (2) or similar to catch the oil drops. As a guide, the optimum position can be obtained if the adjusting screw (1) is tightened as much as possible and then loosened about one turn.

- If the adjusting screw (1) is turned clockwise, the lubrication amount becomes smaller.
- If the adjusting screw (1) is turned counterclockwise, the lubrication amount becomes greater.

10-10. Adjusting the position of the movable knife

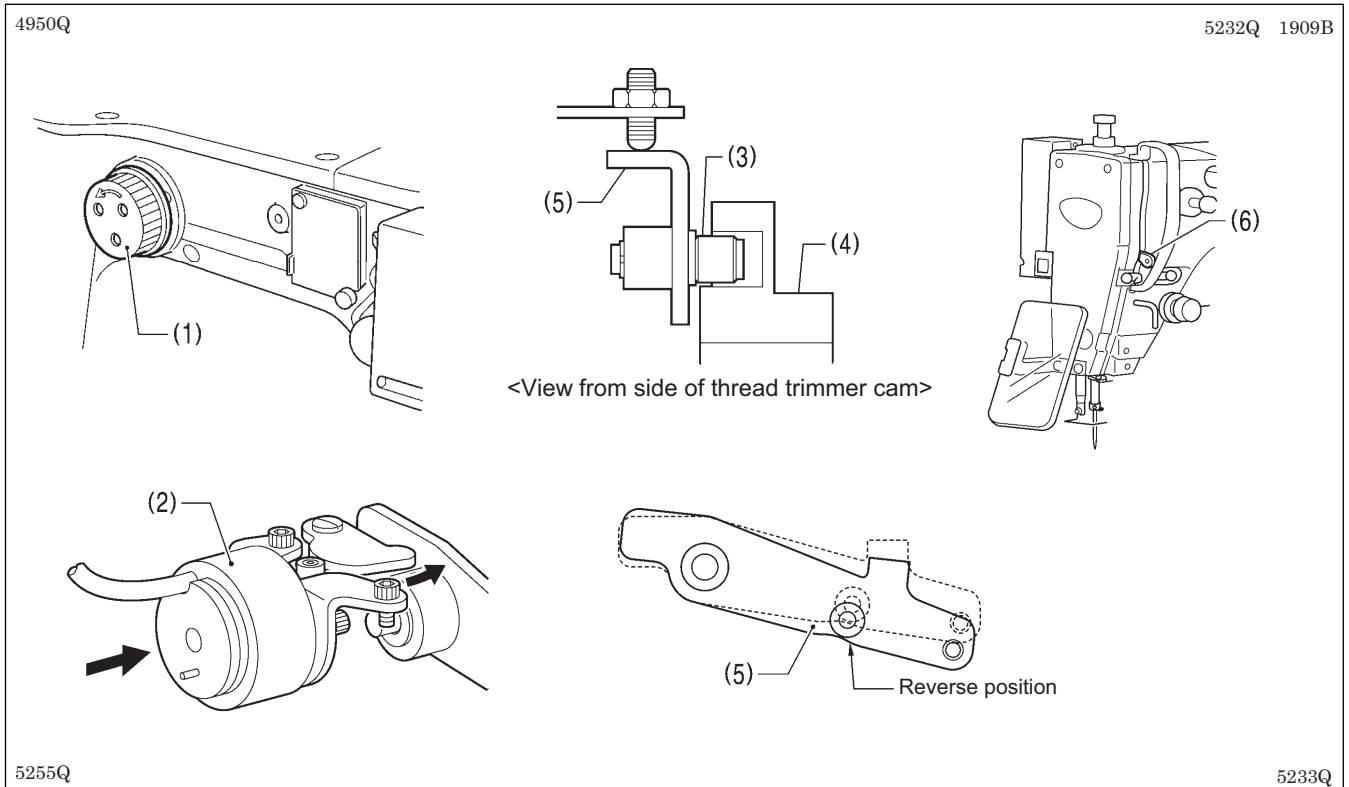

1. Remove the top cover and the solenoid cover, and then tilt back the machine head.
2. Turn the pulley (1) by hand to lower the needle bar to its lowest position, and push the thread trimmer solenoid (2) as far as it will go.
3. With the collar (3) inserted into the groove of the thread trimmer cam (4), turn the pulley (1) by hand to set the driving lever (5) to the reverse position (when the thread take-up (6) is close to its lowest position).

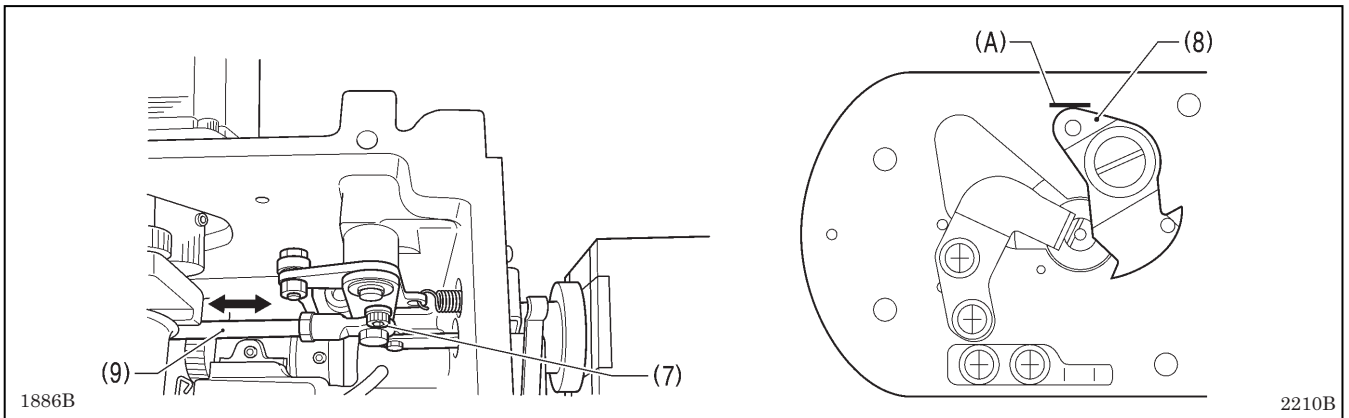

4. Loosen the bolt (7).
5. Move the thread trimming rod H (9) forward or back to adjust so that the ridge line on the movable knife (8) and reference line (A) on the needle plate are aligned.
6. After tightening the bolt (7), check the above position once more.

4950Q

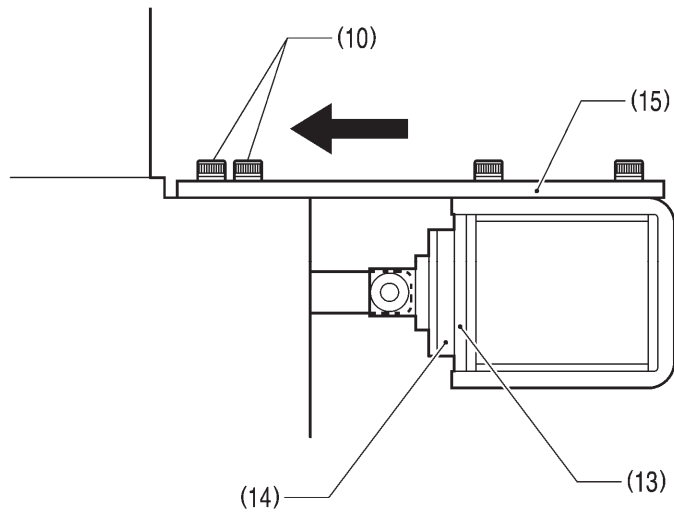
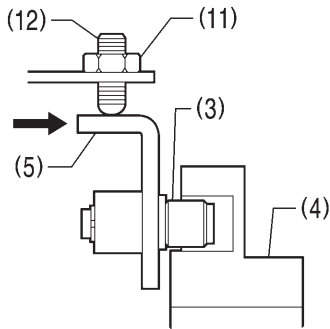
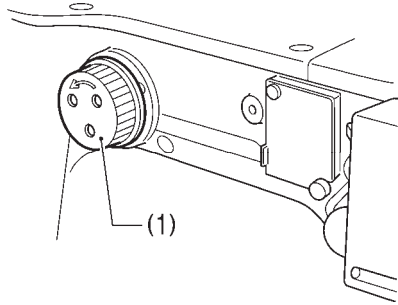

1896B

1889B

7. Turn the pulley (1) by hand to move the needle bar to its lowest position.
8. Loosen the four bolts (10) and the nut (11) until the thread trimmer roller (3) is within the groove in the thread trimmer cam (4). After this, tighten the set screw (12) until the thread trimmer roller (3) is touching the inside of the groove in the thread trimmer cam (4) and then turn it back in the counterclockwise direction by approximately 1/4 of a turn. Then tighten the nut (11).
9. Slide solenoid setting plate U (15) in the direction of the arrow until it pushes against the cover (13) of thread trimmer solenoid B and the cushion (14), and then tighten the four bolts (10).
10. Loosen the nut (11) once more, and then turn the set screw (12) a further 1/4 of a turn in the counterclockwise direction.
11. Tighten the nut (11), and then check that the collar (3) is not touching the inside of the groove in the thread trimmer cam (4). In addition, push the driving lever (5) by hand toward the thread trimmer cam (4) until the collar (3) touches the groove of the thread trimmer cam (4), and then check that the driving lever (5) returns smoothly to its original position when it is released.

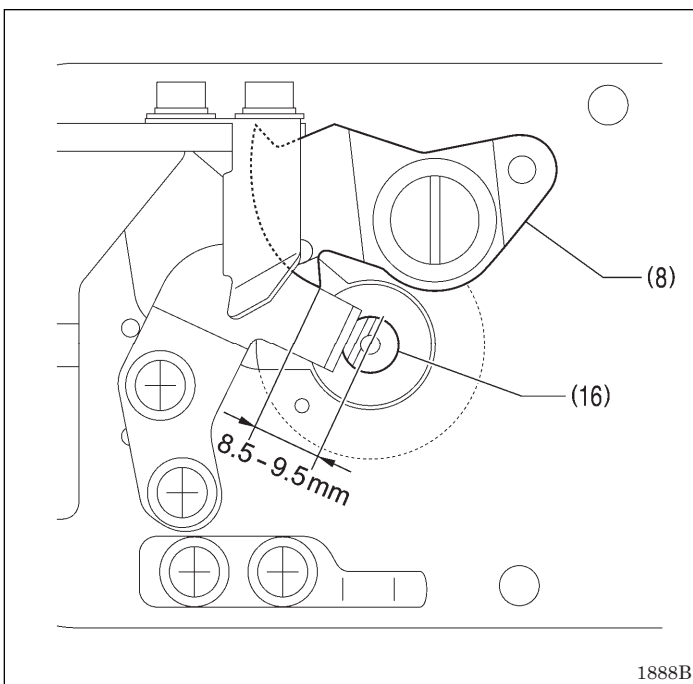

1888B

12. Check that there is a gap of about 8.5 – 9.5 mm between the tip of the movable knife (8) and the center of the hole in the needle hole plate (16) when there is still play between the parts.

10-11. Replacing the movable and fixed knives

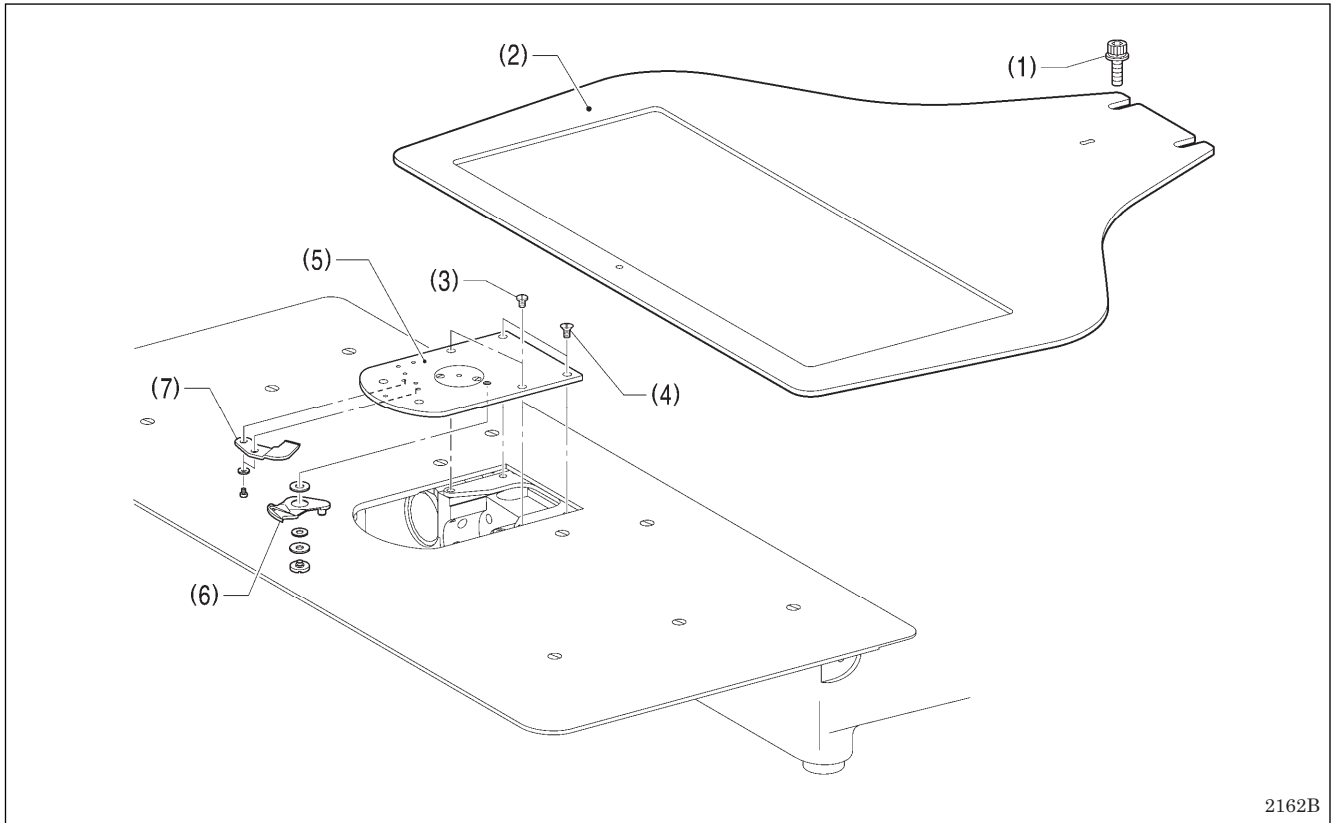

2162B

1. Loosen the two bolts (1) and then remove the feed plate (2).
2. Open the hook cover, remove the two screws (3) and the two flat screws (4), and then remove the needle plate (5).
3. Remove the movable knife (6) and the fixed knife (7).

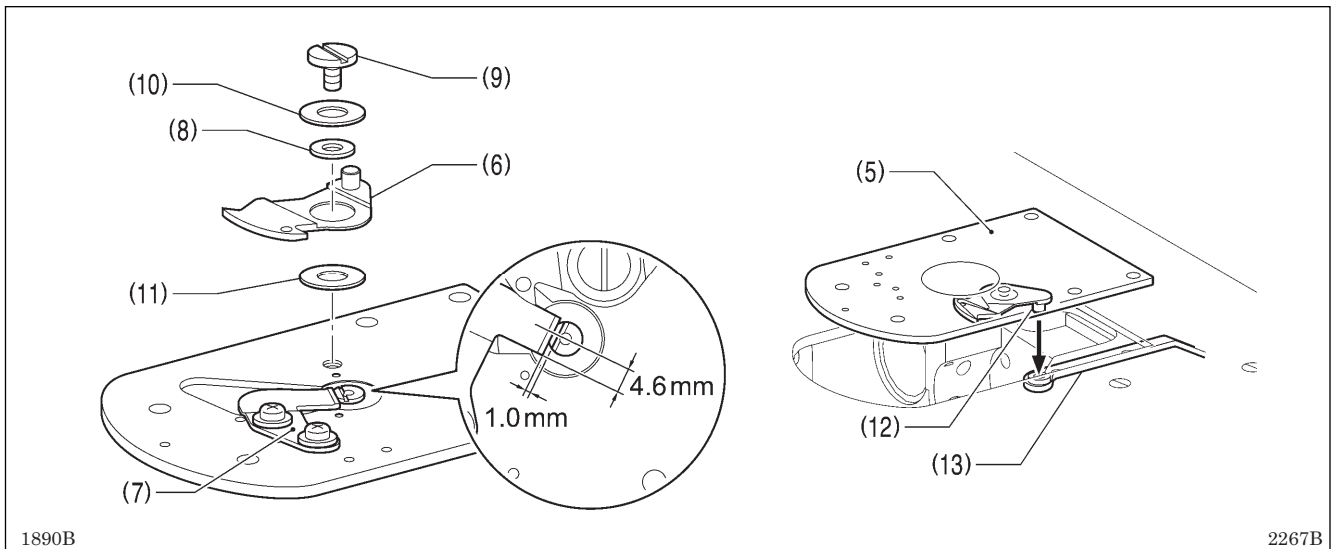

1890B

2267B

4. Install the new fixed knife (7) in the position shown in the illustration.
5. Apply grease to the outside of the collar (8) and to the shoulder screw (9), and then install the new movable knife (6) together with the thrust washer (10) and the movable knife spacer (11).
6. Check that the movable knife (6) and fixed knife (7) cut the thread cleanly. Replace the movable knife spacer with accessory spacers ($t=0.2, 0.3, 0.4$) so that the knives trim the thread accurately.
 - * If the knife pressure is too weak and the thread is not completely cut, use a thinner movable knife spacer.
 - * If the knife pressure is too strong and the movable knife (6) turns stiffly, use a thicker movable knife spacer.
7. Apply grease to the pin (12), place it into the movable knife connecting plate (13), and install it to the needle plate (5).
8. Check that the needle is aligned with the center of the needle hole.

10-11-1. Installing the feed plate

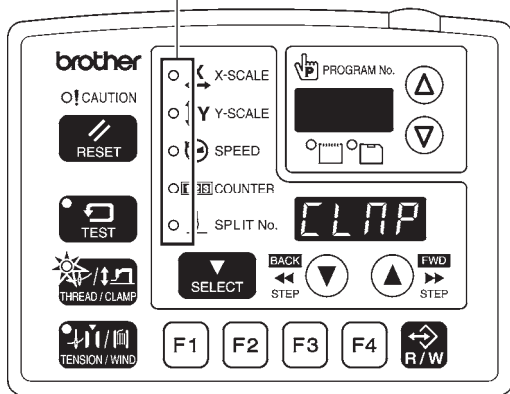
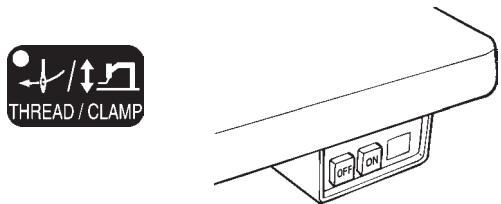
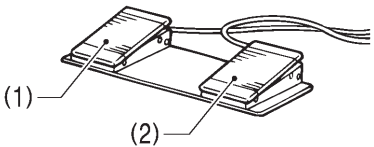
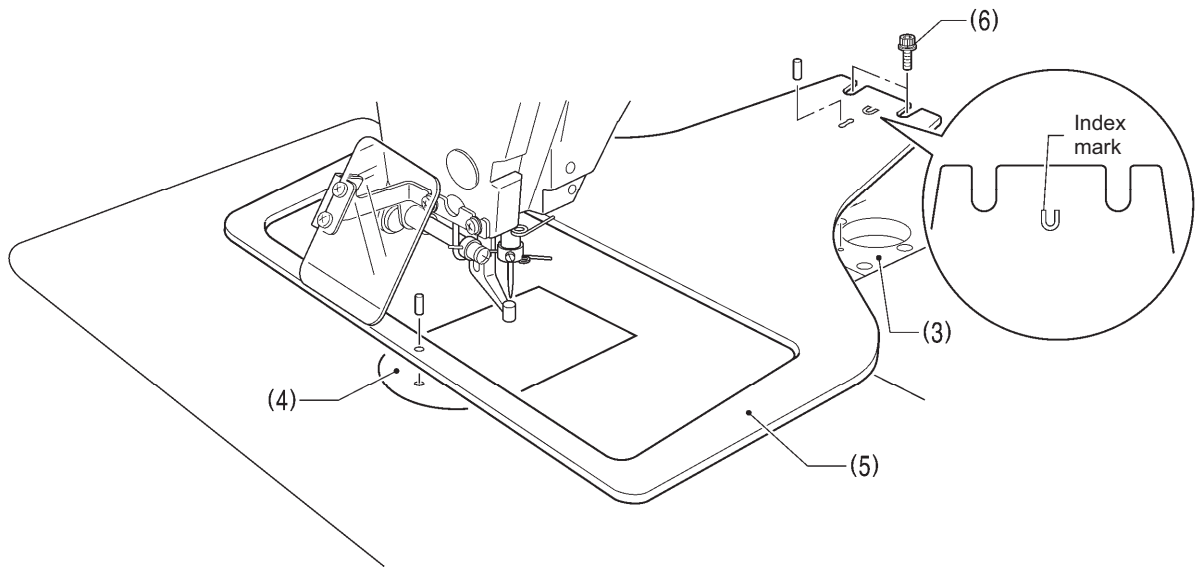
<p>1</p>	<p>All indicators switch off</p>  <p>MENU indicator switches off THREAD/CLAMP indicator illuminates</p>	<p>While pressing the THREAD/CLAMP key, turn on the power switch.</p> <ul style="list-style-type: none"> * Keep pressing the THREAD/CLAMP key until the model name is displayed and the buzzer beeps once.  <ul style="list-style-type: none"> • "CLMP" will appear in the menu display. <p style="text-align: right;">5005Q 4421Q</p>
<p>2</p>		<p>Depress the work clamp switch (1) to lower the work clamp, and then depress the start switch (2).</p> <ul style="list-style-type: none"> • After the home position is detected and the work clamp drops, the feed mechanism will move to the feed plate installation position and then the work clamp will rise. <p style="text-align: right;">4014M</p>
<p>3</p>	 <p>Use a 2 mm diameter pin to align the holes in the X feed bracket (3) and the needle plate (4) with the two holes in the feed plate (5), and then tighten the two bolts (6).</p> <p>NOTE: Install the feed plate so that the surface with the index mark is facing upward.</p> <p style="text-align: right;">2164B</p>	
<p>4</p>	<p>End feed plate installation mode</p> <p style="text-align: right;">Turn off the power.</p>	

10-12. Adjusting the thread wiper

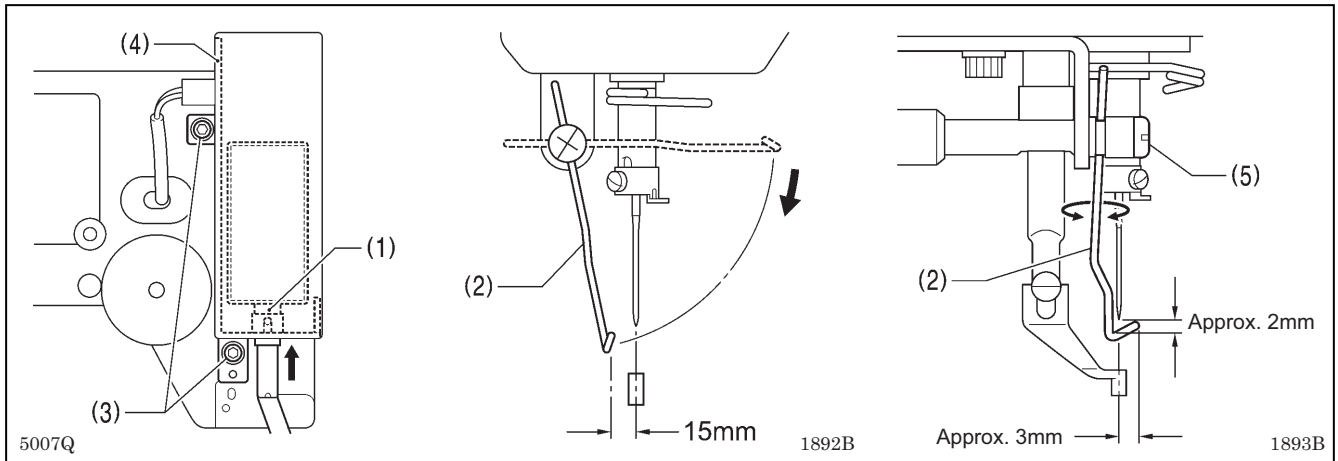

1. Loosen the two screws (3) and shift the entire solenoid setting plate (4) up or down to adjust so that the thread wiper (2) is 15 mm in front of the needle center when the plunger (1) of the thread wiper solenoid is driven to the full stroke.
 2. Loosen the screw (5) and adjust the position of the thread wiper (2) so that the distance from the thread wiper to the tip of the needle is approximately 2 mm and the tip of the thread wiper (2) is approximately 3 mm from the center of the needle when the thread wiper (2) passes below the needle during operation.
- Note: Check that the thread wiper (2) does not touch the finger guard.

10-13. Intermittent presser foot installation position

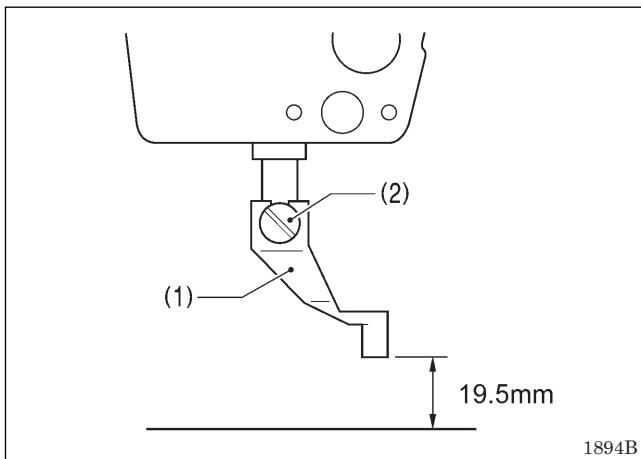

Install the intermittent presser foot (1) with the screw (2) so that the distance from the bottom of the intermittent presser foot to the top of the needle plate is 19.5 mm when the sewing machine is stopped and the intermittent presser foot (1) is raised.

10-14. Changing the intermittent stroke

The intermittent stroke can be adjusted to within 2 – 10 mm by adjusting the position of the stepping clamp connecting rod and changing the installation position of stepping clamp link A.

<Changing the installation position of stepping clamp link A>

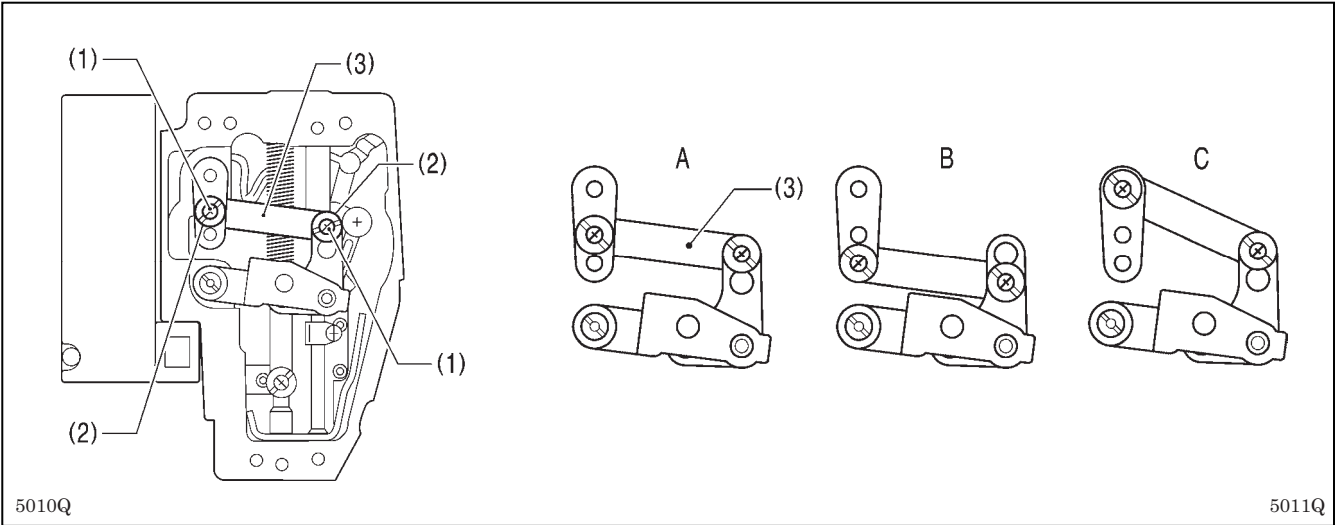

1. Remove the face plate.
 2. Remove the two screws (1) and the two shoulder screws (2), and then remove stepping clamp link A (3).
 3. Change the installation position for stepping clamp link A (3) to either A, B or C above.
- If the position of the stepping clamp connecting rod is adjusted as described in the following at any one of the installation positions, the adjustment range for the intermittent stroke will as given in the following table.

Installation position	Intermittent stroke range	
A	2 – 4.5mm	
B	4.5 – 10mm	
C	0 mm (Intermittent presser foot does not move up and down)	

5012Q

10. STANDARD ADJUSTMENTS

<Stepping clamp connecting rod position adjustment>

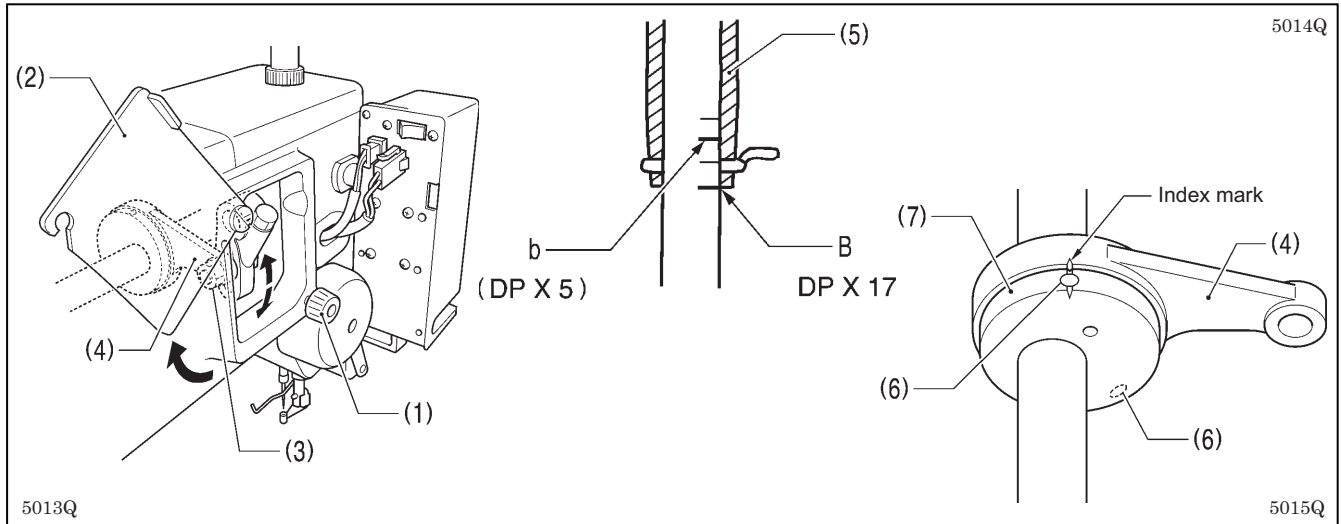

1. Loosen the screw (1), and then open the cover (2).
2. Loosen the nut (3), and then adjust the position of the stepping clamp connecting rod (4).
 - When the stepping clamp connecting rod (4) is raised, the intermittent stroke will increase.
 - When the stepping clamp connecting rod (4) is lowered, the intermittent stroke will decrease.

Next, adjust the needle bar and intermittent presser foot timing.

3. Turn the machine pulley to raise the needle bar from the lowest position until the lowest reference line on the needle bar (reference line B) is aligned with the lower edge of the needle bar bush (5).
(If using a DP x 5 needle, align with the second reference line from the top (reference line b).)
4. Open the top cover and loosen the two set screws (6).
5. Align the index marks on the stepping clamp cam (7) and the stepping clamp connecting rod (4), and then tighten the set screws (6).

Check the following after changing the intermittent stroke.

5016Q 1895B

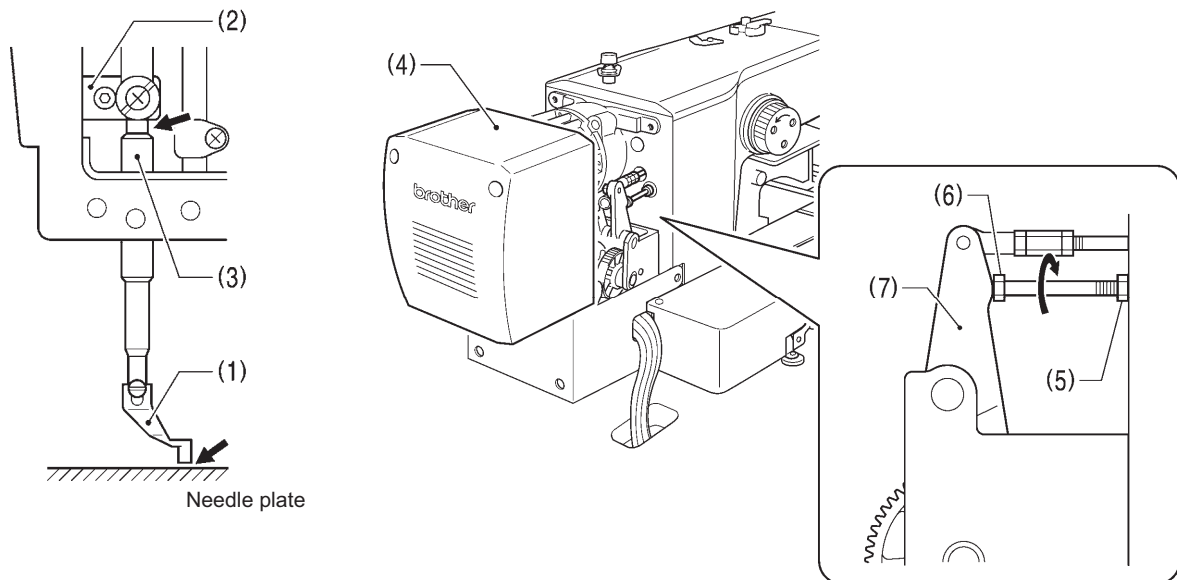

1. With the intermittent presser foot (1) lowered, turn the pulley to move the intermittent presser foot (1) to its lowest position.
2. Check that the intermittent presser foot (1) does not touch the needle plate and that the presser bar clamp (2) does not touch the presser bar bush (3).

<If they are touching>

Remove the motor cover (4).

Loosen the nut (5), and turn the bolt (6) until it is pressing against the intermittent drive lever (7), and then adjust until the two points mentioned above are not touching.

10-15. Adjusting the work clamp lift amount

The maximum lift amount for the work clamp is 30 mm above the top of the needle plate.

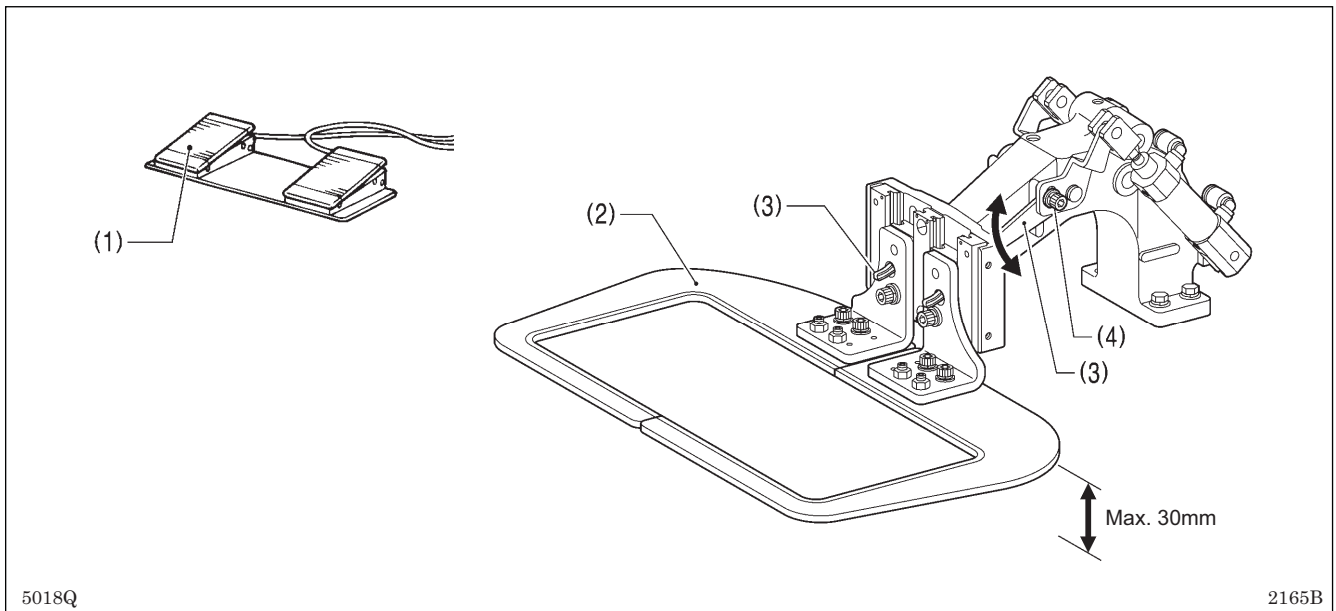

1. Turn on the air, and depress the work clamp switch (1) to raise the work clamp (2).
2. Loosen the two bolts (4) of the work clamp arm lever (3), and move the work clamp arm lever (3) up or down to adjust.

10-16. Adjusting the air pressure

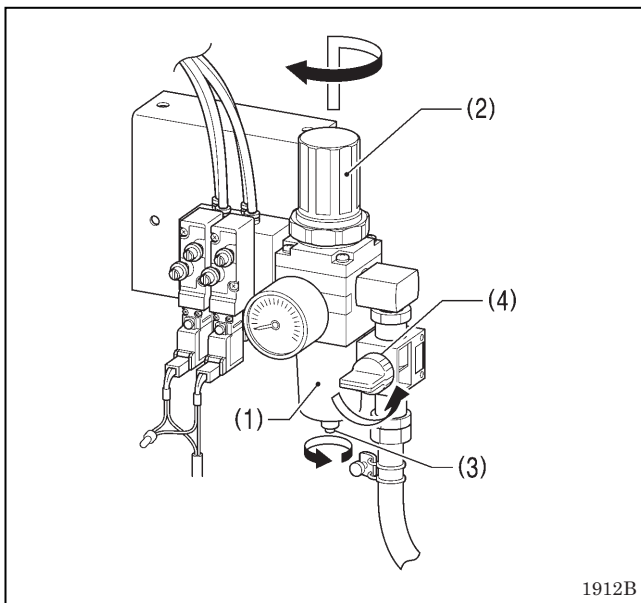

Lift up the handle (2) of the regulator (1) and then turn it to adjust the air pressure to 0.5 MPa.

After adjustment is complete, push the handle (2) downward to lock it.

If water has collected in the bottle of the regulator (1), turn the drain cock (3) in the direction indicated by an arrow to drain the water.

NOTE:

Open the air cock (4) slowly.

11. TABLE OF ERROR CODES

DANGER



Wait at least 5 minutes after turning off the power switch and disconnecting the power cord from the wall outlet before opening the cover of the control box. Touching areas where high voltages are present can result in severe injury.

If a malfunction should occur with the sewing machine, a buzzer will sound and an error code will appear in the display window. Follow the remedy procedure to eliminate the cause of the problem.

Switch-related errors

Code	Cause and remedy
E010	Stop switch was pressed. Press the RESET key to clear the error.
E011	Stop switch was pressed. Press the RESET key to clear the error. Press the ▼ key to move the feed mechanism so that you can continue sewing.
E015	The stop switch was still being pressed, or there is a problem with the stop switch connection. Turn off the power, and then check that connector P13 on the main P.C. board is properly connected.
E016	Problem with the stop switch connection. Turn off the power, and then check that connector P13 on the main P.C. board is properly connected.
E025	The power was turned on while the start switch was still being depressed, or the start switch was depressed without the work clamp being lowered. If the power has been turned on while the start switch was still depressed, turn off the power and check the start switch. If the start switch was depressed without lowering the work clamp, depress the work clamp switch to lower the work clamp.
E035	The work clamp switch is depressed. Turn off the power, and then check the work clamp switch.
E036	A foot switch that does not match specifications is connected, or work clamp mode has not been set correctly. Use a foot switch that matches specifications, or initialize the memory switch settings.
E050	Machine head tilting was detected after the power was turned on. Turn off the power, and then return the machine head to its original position. Check that connector P9 on the main P.C. board is properly connected.
E051	Machine head tilting was detected while the sewing machine was operating. Turn off the power, and then check that connector P9 on the main P.C. board is properly connected.
E055	Machine head tilting was detected when the power was turned on. Turn off the power, and then return the machine head to its original position. Check that connector P9 on the main P.C. board is properly connected.
E065	An operation panel key was still being pressed when the power was turned on, or key is faulty. Turn off the power and check the operation panel.

Upper shaft motor-related errors

Code	Cause and remedy
E110	Needle up stop position error. Turn the machine pulley until the point where the error display disappears.
E111	Upper shaft did not stop at the needle up stop position when the sewing machine stopped. Turn the machine pulley until the point where the error display disappears.
E120	Needle drop signal could not be detected. Turn off the power, and then check the synchronizer connection.
E121	Thread trimming was not completed. Turn off the power, and then check if the cutting edges of the fixed knife and movable knife are damaged or worn.
E130	Sewing machine motor stopped due to a problem, or synchronizer is faulty. Turn off the power, and then turn the machine pulley and check if the sewing machine has locked up. Check that connectors P4 and P5 on the power supply motor P.C. board are properly connected.
E131	Synchronizer is faulty. Turn off the power, and then check that connector P5 on the power supply motor P. C. board is properly connected.
E132	Problem detected with sewing machine motor operation. Turn off the power, and then check that connector P4 on the power supply motor P.C. board is properly connected.
E133	Sewing machine motor stopping position is incorrect. Turn off the power, and then check that connector P5 on the power supply motor P.C. board is properly connected.
E150	Sewing machine motor is overheating, or temperature sensor is faulty. Turn off the power, and then check the sewing machine motor. (When sewing data with a small number of stitches (15 stitches or less) is sewn repeatedly (short cycle operation), the upper shaft motor may overheat and the "E150" error code may be generated.)

Feed mechanism-related errors

Code	Cause and remedy
E200	X-feed motor home position cannot be detected. Problem with X -feed motor or poor X home position sensor connection. Turn off the power, and then check that connector P10 on the PMD P.C. board and connector P20 on the main P.C. board are properly connected.
E201	X-feed motor stopped due to a problem. Turn off the power, and then check if there are any problems in the X-feed direction.
E202	Problem with X-feed motor or Y-feed motor home position adjustment data. Re-adjust the home position.
E204	X-feed motor stopped due to a problem during sewing. Turn off the power, and then check if there are any problems in the X-feed direction.
E205	X-feed motor stopped due to a problem while moving to the sewing start position. Turn off the power, and then check if there are any problems in the X-feed direction.
E206	X-feed motor stopped due to a problem during test feeding. Turn off the power, and then check if there are any problems in the X-feed direction.
E207	X-feed motor stopped due to a problem during programming. Turn off the power, and then check if there are any problems in the X-feed direction.
E210	Y-feed motor home position cannot be detected. Problem with Y-feed motor or poor Y home position sensor connection. Turn off the power, and then check that connector P8 on the PMD P.C. board and connector P4 on the main P.C. board are properly connected.
E211	Y-feed motor stopped due to a problem. Turn off the power, and then check if there are any problems in the Y-feed direction.
E214	Y-feed motor stopped due to a problem during sewing. Turn off the power, and then check if there are any problems in the Y-feed direction.
E215	Y-feed motor stopped due to a problem while moving to the sewing start position. Turn off the power, and then check if there are any problems in the Y-feed direction.
E216	Y-feed motor stopped due to a problem during test feeding. Turn off the power, and then check if there are any problems in the Y-feed direction.
E217	Y-feed motor stopped due to a problem during programming. Turn off the power, and then check if there are any problems in the Y-feed direction.

11. TABLE OF ERROR CODES

Work clamp-related errors

Code	Cause and remedy
E300	Work clamp home position cannot be detected. Problem with work clamp motor or poor work clamp home position sensor connection. Turn off the power, and then check that connector P3 on the PMD P.C. board and connector P5 on the main P.C. board are properly connected.
E301	Intermittent presser foot raised or lowered position cannot be detected. Turn off the power, and then check if there are any problems in the intermittent presser foot vertical direction.
E303	Problem with work clamp motor home position adjustment data. Re-adjust the home position.

Communication and memory-related errors

Code	Cause and remedy
E401	Connection communication error with power supply motor P. C. board detected when power was turned on. Turn off the power, and then check that connector P6 on the power supply motor P.C. board and connector P17 on the main P.C. board are properly connected.
E402	Communication error with programmer detected when power is turned on. Turn off the power, and then check that connector P7 on the main P.C. board is properly connected.
E403	Connection error with PMD P. C. board detected when power was turned on. Turn off the power, and then check that connector P1 on the PMD P.C. board is properly connected.
E410	Communication error with main P. C. board detected. Turn off the power, and then turn it back on again.
E411	Communication error with power supply motor P. C. board detected. Turn off the power, and then turn it back on again.
E412	Communication error with programmer detected. Turn off the power, and then turn it back on again.
E413	Communication error with PMD P. C. board detected. Turn off the power, and then turn it back on again.
E420	No CF card is inserted.
E421	Program contents are incorrect and cannot be used, or no data. Check that the CF card or floppy disk contains data with this program number.
E422	Error occurred while reading the CF card or floppy disk. Check the data on the CF card or floppy disk.
E424	Insufficient free space on the CF card, or data cannot be written to the floppy disk. Use a different CF card. Check if the floppy disk is write-protected and if it has enough free space.
E425	Error occurred while writing to the CF card or floppy disk. Use the specified type of CF card. Check if the floppy disk is write-protected and if it has enough free space.
E426	R/W key has not been pressed. Press the R/W key to load the data.
E427	CF card or floppy disk does not contain any data with this program number. Check the program number. Data that has already been loaded into internal memory can be used without having to press the R/W key again.
E430	Data cannot be backed up to main P.C. board. Turn off the power, and then turn it back on again.
E440	Data memory error on main P.C. board. Turn off the power, and then turn it back on again.
E450	Model selection cannot be read from the machine head memory. Turn off the power and check that connector P3 on the power supply motor P.C. board is properly connected.
E451	Data cannot be backed up to machine head memory. Turn off the power, and then turn it back on again.
E452	Machine head memory is not connected. Turn off the power, and then check that connector P3 on the power supply motor P.C. board is properly connected.
E474	Internal memory is full and copying is not possible. Clear the sewing data.

Data editing-related errors

Code	Cause and remedy
E500	The enlargement ratio setting caused the sewing data to extend outside the sewing area. Set the enlargement ratio again.
E501	Sewing data that exceeds the sewing machine's sewing area was loaded. Check the size of the sewing data.
E502	The enlargement ratio caused the data pitch to exceed the maximum pitch of 12.7 mm. Set the enlargement ratio again.
E510	Invalid code in sewing data. Reload the data from the CF card or floppy disk.
E511	No end code has been input into sewing data. Input an end code, or change the program number.
E512	Number of stitches exceeds allowed maximum.
E520	Extended option output number already exists. Change the extended option output number. If not using the extended option output, initialize the data to clear the extended option output data.
E530	Changing program number is prohibited.

P.C. board-related errors

Code	Cause and remedy
E700	Abnormal rise in power supply voltage. Turn off the power and check the input voltage.
E701	Abnormal rise in sewing machine motor drive voltage. Turn off the power, and then check the voltage.
E705	Abnormal drop in power supply voltage. Turn off the power and check the input voltage.
E710	Abnormal current detected in sewing machine motor. Turn off the power, and then check if there are any problems with the sewing machine.
E711	Abnormal current detected in X-feed motor. Turn off the power, and then check if there are any problems in the X-feed direction.
E712	Abnormal current detected in Y-feed motor. Turn off the power, and then check if there are any problems in the Y-feed direction.
E713	Abnormal current detected in work clamp motor. Turn off the power, and then check if there are any problems with the X-feed mechanism, Y-feed mechanism or work clamp lifter.
E730	External error input (AIRSW) detected. Turn off the power, and then check the air pressure.
E740	Cooling fan does not operate. Turn off the power, and then check if the cooling fan is blocked with scraps of thread. Check that connector P22 on the main P.C. board is properly connected.

If an error code that is not listed above appears or if carrying out the specified remedy does not solve the problem, contact the place of purchase.

12. TROUBLESHOOTING

- Please check the following points before calling for repairs or service.
- If the following remedies do not fix the problem, turn off the power switch and consult a qualified technician or the place of purchase.

CAUTION



Turn off the power switch and disconnect the power cord before carrying out troubleshooting.
If the foot switch is depressed by mistake, the sewing machine might start operating and injury could result.

Items with a "*" in the "Reference" column should only be checked by a qualified technician.

Problem	Cause	Remedy	Reference
Work clamp does not lift.	Work clamp moves stiffly.	Apply a suitable amount of grease to the sliding parts of the work clamp.	
Work clamp does not drop.	Air tube of air cylinder is bent or damaged.	Straighten the bend in the tube or replace the tube.	
Work clamp lift amount is incorrect.	Work clamp arm lever position is incorrect.	Adjust the position of the work clamp arm lever.	P. 64
Work clamp does not lift to the maximum height.	Cylinder joint position is incorrect.	Adjust the position of the cylinder joint.	
Thread wiper does not operate correctly.	The thread wiper is obstructing the needle.	Adjust the height of the thread wiper.	P. 61
		Adjust the stroke of the thread wiper.	P. 61
	Thread wiper position is incorrect.	Adjust the stroke of the thread wiper.	P. 61
Lower thread winds to one side.	Bobbin winder tension assembly height is incorrect.	Adjust the height of the bobbin winder tension assembly.	P. 21
Lower thread winding amount is incorrect.	Bobbin presser position is incorrect.	Adjust the position of the bobbin presser.	P. 21
Thread slips out of the needle.	Stitches being skipped at the sewing start.	Refer to "Skipped stitches occur".	P. 70
	Upper thread trailing length is uneven.	Adjust the sub tension.	P. 23
Thread unravelling at sewing start.	Rotary hook pulls the upper thread at the sewing start.	Use the programmer to reduce the intermittent presser foot height so that the upper thread is pressed by the intermittent presser foot at the 1st stitch.	*

Problem	Cause	Remedy	Reference
Upper thread breaks.	Upper thread tension is too strong.	Adjust the upper thread tension.	P. 23
	Needle is incorrectly installed.	Install the needle correctly.	P. 19
	Thread is too thick for the needle.	Select a thread that matches the needle.	P. 23
	Thread take-up spring tension and height are incorrect.	Adjust the tension and height of the thread take-up spring.	P. 54
	Damage or burring of the rotary hook, needle hole plate, needle or thread path.	Repair or replace the problem part.	
	Thread breaking from heat (Synthetic thread).	Use a needle cooler.	P. 19
	Thread is threaded incorrectly.	Thread the thread correctly.	P. 19
	Damage to the hook stopper.	Buff the hook stopper to remove the damage, or replace the hook stopper.	
Lower thread breaks.	Lower thread tension is too strong.	Adjust the lower thread tension.	P. 23
	Damage to the needle hole plate or bobbin case.	Repair or replace the problem part.	
Skipped stitches occur.	Clearance between needle and rotary hook tip is too great.	Adjust the needle clearance.	P. 56
	Needle and rotary hook timing is incorrect.	Adjust the needle bar lift amount.	P. 55
	The needle guard is covering the needle more than necessary.	Adjust the needle guard.	P. 55
	Needle is bent.	Replace the needle.	
	Needle is incorrectly installed.	Install the needle correctly.	P. 19
	Intermittent height of intermittent presser foot is too high.	Adjust the intermittent height of the intermittent presser foot.	P. 30
Needle is broken.	Clearance between needle and rotary hook tip is too great.	Adjust the needle clearance.	P. 56
		Adjust the needle bar lift amount.	P. 55
	Needle is bent.	Replace the needle.	
	Needle deflection	Select a needle that is suitable for the sewing conditions. Reduce the sewing speed.	P. 23
	Needle is too thin.	Select a needle that is suitable for the sewing conditions.	P. 23
Thread jamming.	Thread take-up spring tension and height are incorrect.	Adjust the tension and height of the thread take-up spring.	P. 54
	Needle and rotary hook timing is incorrect.	Adjust the needle bar lift amount.	P. 55

12. TROUBLESHOOTING

Problem	Cause	Remedy	Reference	
Upper thread is not trimmed.	Movable knife is not cutting cleanly.	Replace with a new one.	P. 59	
	Fixed knife is not cutting cleanly.	Sharpen the fixed knife or replace it with a new one.	P. 59	
	Movable knife is not picking up the upper thread.	Adjust the position of the movable knife.	P. 57	
		Adjust the needle bar lift amount.	P. 55	
	Movable knife is not picking up the upper thread because the last stitch is being skipped.	Refer to "Skipped stitches occur".	P. 70	
	Movable knife position is incorrect.	Adjust the position of the movable knife.	P. 57	
	Sub tension is too weak.	Turn the sub tension nut to adjust the tension.	P. 23	
Poor stitch finish on underside of material.	Incorrect tightening of the upper thread.	Adjust the upper thread tension.	P. 23	
	Upper thread trailing length is uneven.	Adjust the sub tension.	P. 23	
Incorrect tightening of the thread	Upper thread tension is too weak.	Adjust the upper thread tension.	P. 23	
	Lower thread tension is too weak.	Adjust the lower thread tension.	P. 23	
	Thread take-up spring tension and height are incorrect.	Adjust the tension and height of the thread take-up spring.	P. 54	
	Position of arm thread guide R is incorrect.	Adjust the position of arm thread guide R.	P. 53	
	Intermittent height of intermittent presser foot is too low.	Adjust the intermittent height of the intermittent presser foot.	P. 30	
	Upper thread does not release correctly from hook stopper.	Adjust the overlapping amount for the inner rotary hook and hook stopper.	P. 56	
	Feed timing is too fast.	Retard the feed timing.	*	
	Upper thread forms the seam poorly.	Select the correct needle hole plate.		
		Smooth the thread path.		
		Select the correct intermittent presser foot.		
		Increase the thickness of the feed plate.		
	Thread scraps and dust in rotary hook.	Clean away the thread scraps and dust.	P. 51	
	Needle is too thin.	Replace the needle with one with a higher count.		
Damage to the hook stopper.	Buff the hook stopper to remove the damage, or replace the hook stopper.			

Problem	Cause	Remedy	Reference	
Upper thread trailing length is irregular.	Thread take-up spring tension and height are incorrect.	Adjust the tension and height of the thread take-up spring.	P. 54	
	Sub tension is too weak.	Turn the sub tension nut to adjust the tension.	P. 23	
	Fixed knife is not cutting cleanly.	Sharpen the fixed knife or replace it with a new one.	P. 59	
Lower thread is protruding from the top of the material.	Thread take-up spring tension is too strong.	Adjust the tension of the thread take-up spring.	P. 54	
	Insufficient thread take-up amount.	Adjust the position of arm thread guide R.	P. 53	
Hitch stitch sewing range is too great.	Lower thread tension is too weak.	Adjust the lower thread tension.	P. 23	
	Lower thread is threaded incorrectly.	Pass the lower thread through the window of the inner rotary hook.	P. 22	
	Sewing speed is too high.	Reduce the sewing speed.	P. 28	
	Needle is incorrectly installed.	Install the needle correctly.	P. 19	
	Upper thread position is incorrect.	Select the correct intermittent presser foot.		
		Grind the cylinder of the intermittent presser foot so that it does not touch the thread.		
Needle is shaking.	Replace the needle with one with a higher count.			
Thread trailing length underneath the material is too short.	Fixed knife position is too close to the needle hole plate.	Move the fixed knife position away from the needle hole plate.	P. 59	
Sewing machine does not operate when the power is turned on and the foot switch is depressed.	Machine head switch does not work.	Check if the machine head switch cord is disconnected.	P. 11	
		Adjust the position of the machine head switch.	P. 8 P. 53	
		If the machine head switch is malfunctioning, replace it with a new one.		

13. 7-SEGMENT DISPLAY

0	1	2	3	4	5	6	7	8	9
A	B	C	D	E	F	G	H	I	J
K	L	M	N	O	P	Q	R	S	T
U	V	W	X	Y	Z				

brother®



INSTRUCTION MANUAL

BROTHER INDUSTRIES, LTD. <http://www.brother.com/>

1-5, Kitajizoyama, Noda-cho, Kariya 448-0803, Japan. Phone : 81-566-95-0088

© 2010 Brother Industries, Ltd. All Rights Reserved.
This is the original instructions.

BAS-326G PS
SB0471-101 E
2010.03. B (1)